

YR3

Unità rotante a doppia cremagliera

- Combinazione di azionamento a doppio pistone più piastra rotante e sistema rotativo a doppia cremagliera
- Assenza di gioco
- Angolo regolabile in base alle proprie esigenze
- Possibilità di scelta tra le viti di regolazione e deceleratori idraulici interni
- Fori di centraggio su corpo e tavola per montaggi accurati
- Montaggio diretto del carico sulla tavola
- Ricavate scanalature sul corpo per l'inserimento dei sensori magnetici di tipo a scomparsa, due per ogni lato

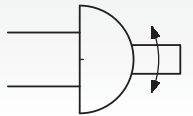

CARATTERISTICHE TECNICHE

Temperatura ambiente	0 ÷ 50 °C
Fluido	aria filtrata con o senza lubrificazione
Pressione di esercizio	1,5 ÷ 7 bar
Angolo di rotazione	180°
Campo di rotazione	0° ÷ 190°
Alessaggi	Ø 10 - 12 - 15 - 18 - 20 - 25 - 28 - 32 - 40 - 50 - 63 mm

CARATTERISTICHE COSTRUTTIVE

Corpo	alluminio
Testate	alluminio
Tavola rotante	alluminio
Cremagliera	acciaio inox
Pignone	acciaio al carbonio
Guarnizione	gomma nitrilica (NBR)
Paracolpi	gomma nitrilica (NBR)
Magnete	standard

CHIAVE DI CODIFICA

Y	R	3	0	1	0	
1		2		3		

1 Serie

YR3 = Unità rotante a doppia cremagliera

2 Alesaggio (mm)

003 = Ø10	070 = Ø28
007 = Ø12	100 = Ø32
010 = Ø15	200 = Ø40
020 = Ø18	300 = Ø50
030 = Ø20	500 = Ø63
050 = Ø25	

3 Variante

D = Deceleratori idraulici (Ø15 ÷ 63)

Peso

	YR3003	YR3007	YR3010	YR3020	YR3030	YR3050	YR3070	YR3100	YR3200	YR3300	YR3500
Kg	0,150	0,250	0,530	0,990	1,290	2,100	2,890	4,100	7,650	8,960	11,170

Coppia

	YR3003	YR3007	YR3010	YR3020	YR3030	YR3050	YR3070	YR3100	YR3200	YR3300	YR3500
∅	10	12	15	18	20	25	28	32	40	50	63
Nm	0,3	0,6	1,5	2,2	3,2	5,5	7,5	9,8	19	31	45

Coppia teorica a 5 bar

Max energia cinetica
assorbibile (J)

	YR3003	YR3007	YR3010	YR3020	YR3030	YR3050	YR3070	YR3100	YR3200	YR3300	YR3500
Con vite di regolazione	0,002	0,006	0,007	0,025	0,048	0,81	0,24	0,32	0,56	1	1,5
Con deceleratori idraulici	-	-	0,039	0,116	0,116	0,294	1,1	1,6	2,9	3,5	5,2

Carichi consentiti

Carico	Carico laterale (N)	Carico tavola rotante (N)		Torsione (Nm)
		(P1)	(P2)	
YR3003	33	48	48	1,1
YR3007	54	71	71	1,5
YR3010	70	78	74	2
YR3020	140	130	130	3,5
YR3030	185	188	358	4,8
YR3050	300	285	442	9
YR3070	333	296	476	12
YR3100	390	493	706	18
YR3200	543	740	1009	25
YR3300	850	950	1500	30
YR3500	1200	1400	2100	38

1

Direzione carichi

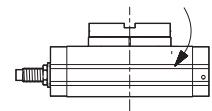
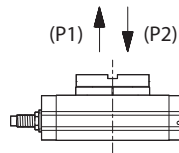
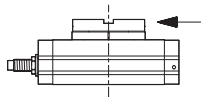

Carico trasversale e flessione

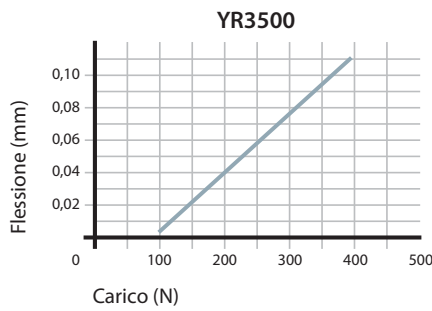
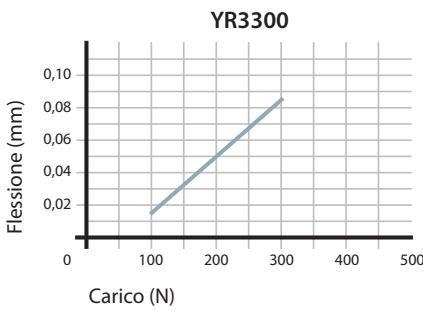
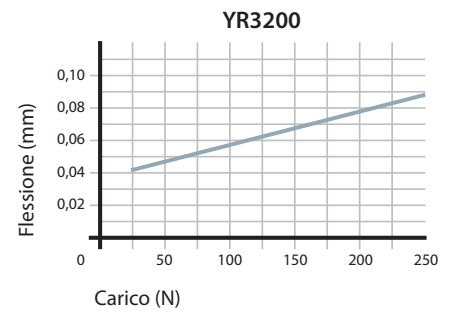
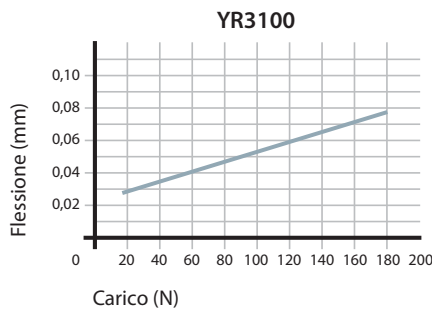
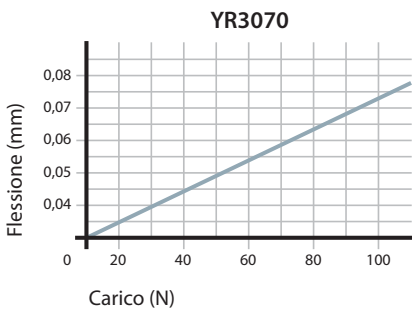
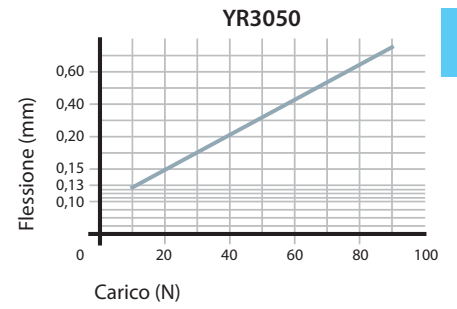
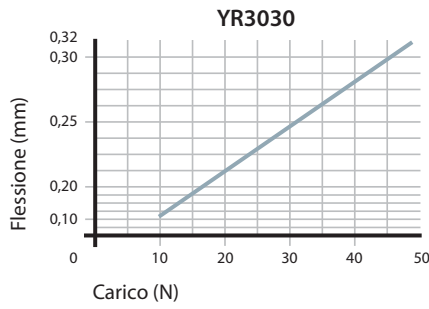
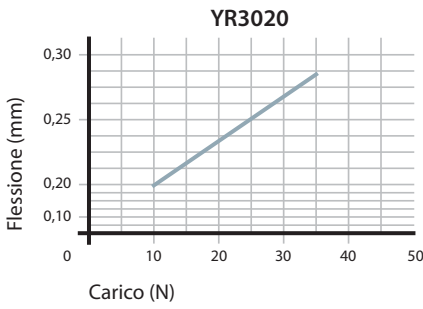
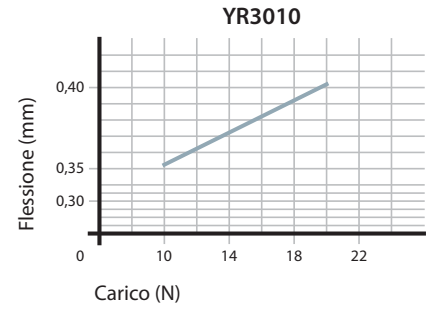
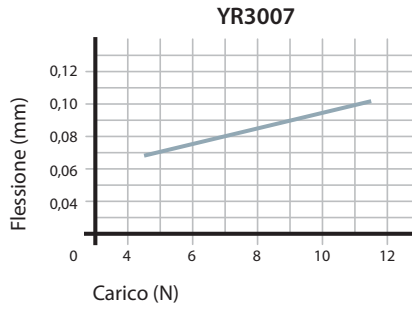
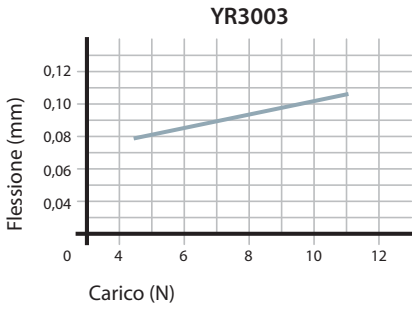
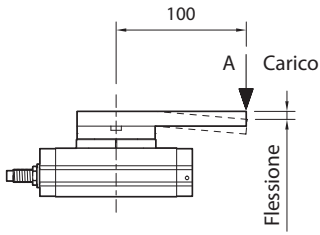

1
CILINDRI

Direzione di rotazione e angolo di rotazione

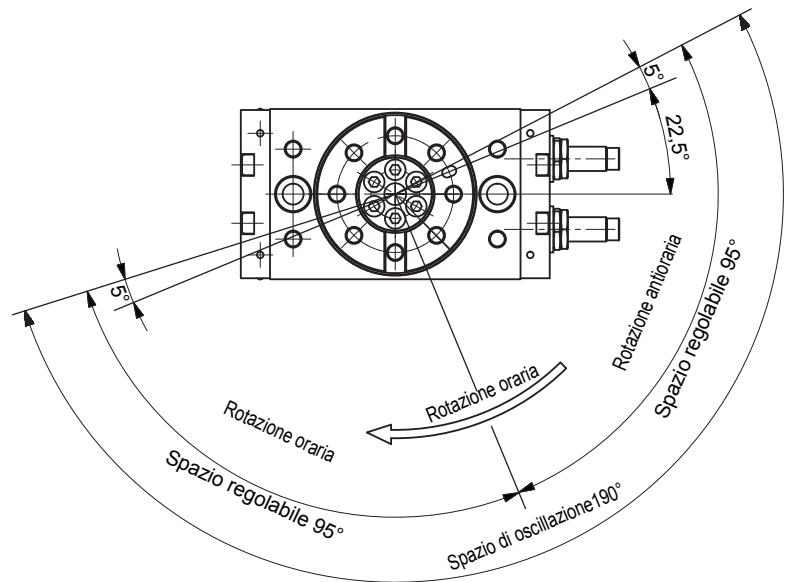
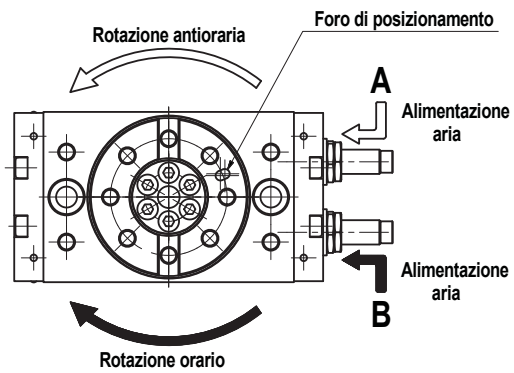

1

YR3 Ø 10 ÷ 12

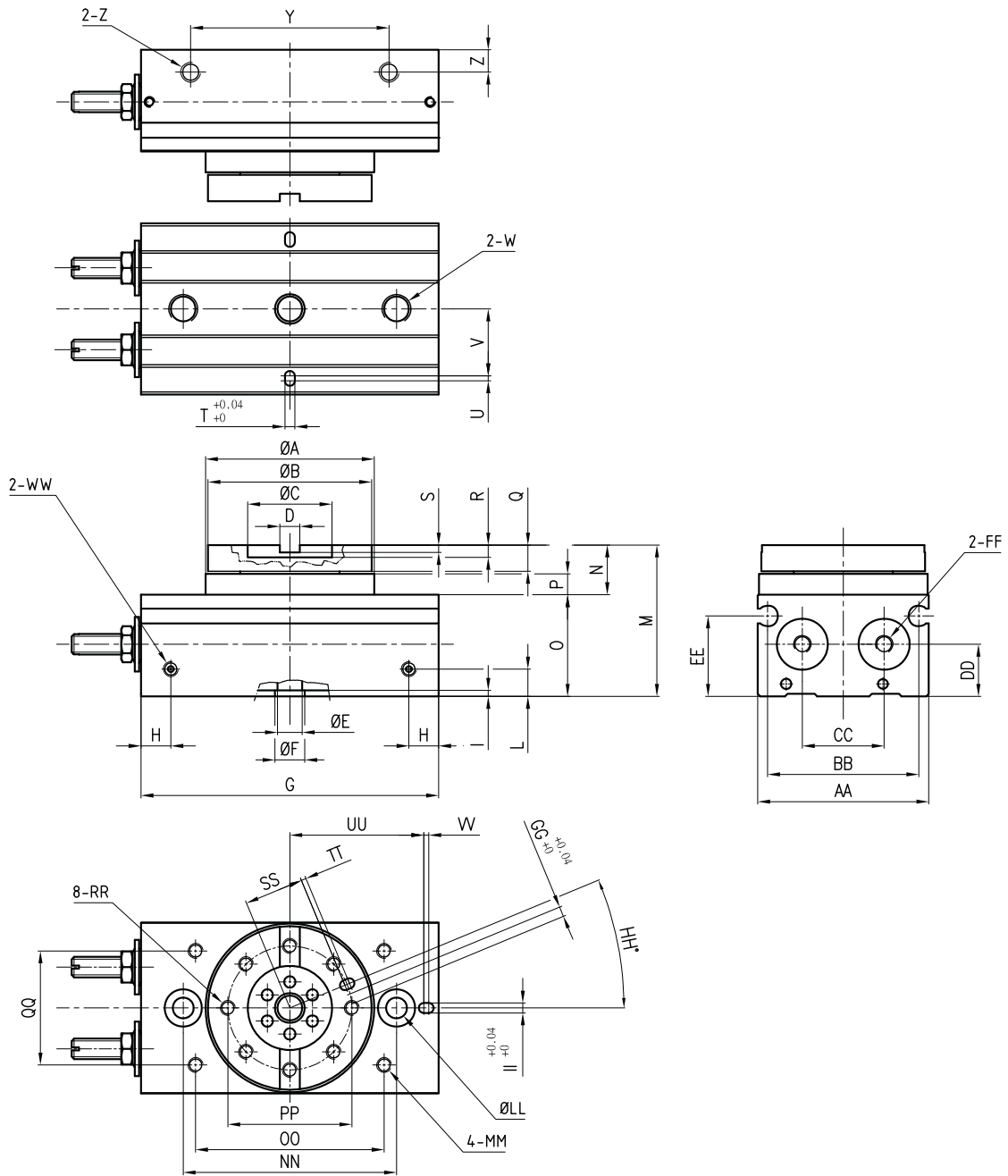

	A	B	C	D	E	F	G	H	I	L	M	N	O	P	Q	R	S	T	U	V	W	X	Y	Z
YR3003	34	33	17	4	5	6	60	6	1,2	5,5	30,5	10	20,5	4,2	5,3	2,5	1,5	2	1	13,5	M5x0,8	4,5	40	M4x0,7
YR3007	40	39	20	5	6	7	73,5	9	1,2	5,5	34,5	11,5	23	4,5	6,5	2,5	2	3	1	15,5	M5x0,8	4,5	50	M5x0,8

	AA	BB	CC	DD	EE	FF	GG	HH	II	LL	MM	NN	OO	PP	QQ	RR	SS	TT	UU	VV	WW
YR3003	34,5	30,5	16,5	10,5	16,2	M3x0,5	2	22,5°	2	4,2	M3x0,5	43	38	25	23	M3,0,5	12	1	27	1	M3x0,5
YR3007	41	37	19,2	12,5	17	M5x0,8	3	22,5°	3	4,2	M4x0,7	50	45	29	30	M4x0,7	14	1	32,5	1	M5x0,8

YR3 Ø 15 ÷ 28

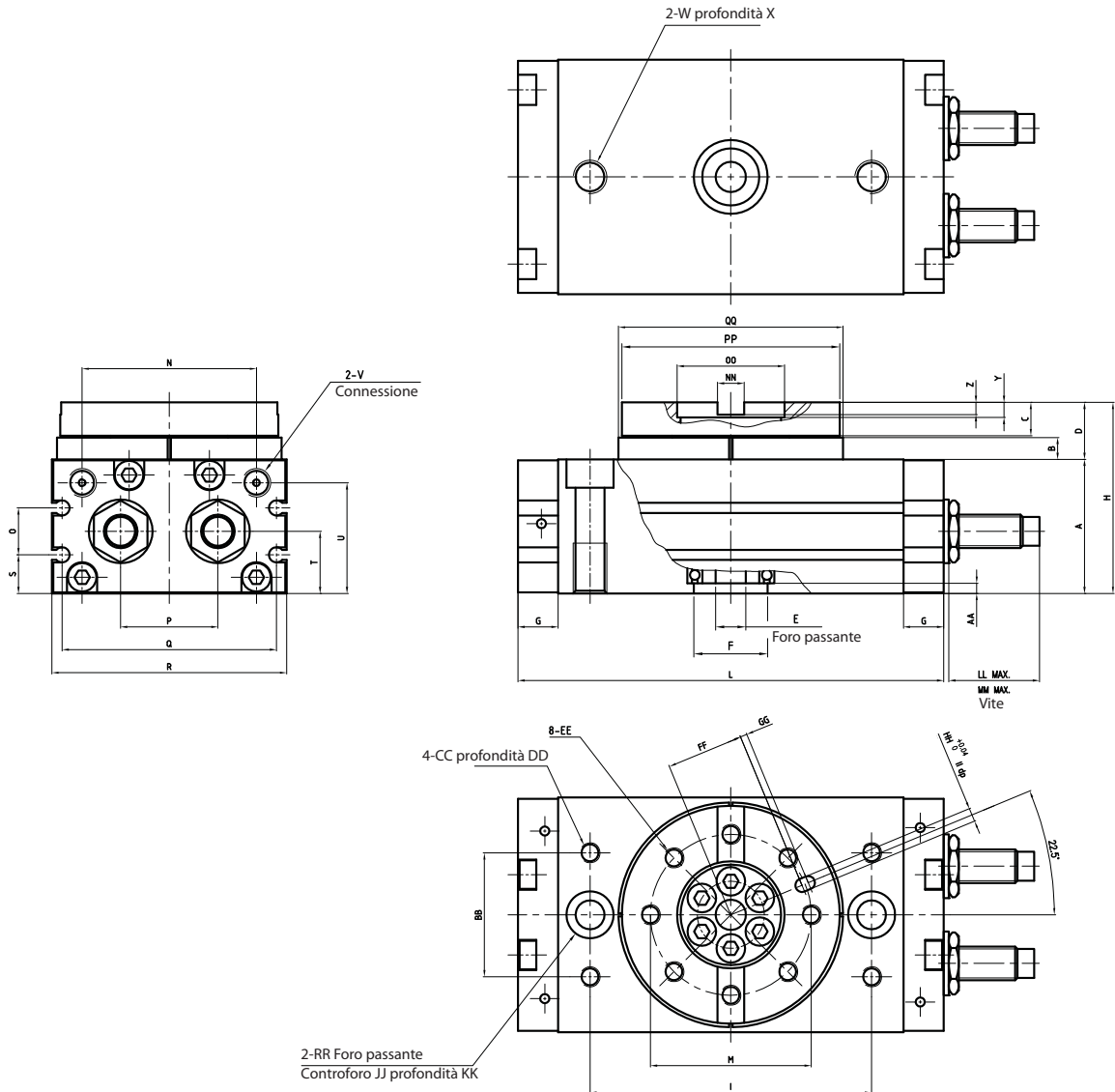

	A	B	C	D	E	F	G	H	I	L	M	N	O	P	Q	R	S	T	U	V	W
YR3010D	34	4,5	8	13	Ø5	Ø15	9,5	47	60	92	Ø32	35	13	18	44	50	9	15,5	28,2	M5x0,8	M8x1,25
YR3020D	37	6,6	9,7	17	Ø9	Ø17	12	54	76	117	Ø43	50,8	12	27,5	59	65	10	16	28,6	M5x0,8	M10x1,5
YR3030D	40	6,5	10	17	Ø9	Ø22	12	57	84	127	Ø48	52	14	29	64	70	11,5	18,5	33	G1/8	M10x1,5
YR3050D	46	7,5	12	20	Ø10	Ø26	15,5	66	100	152	Ø55	62	15	38	74	80	14,5	22	37,5	G1/8	M12x1,75
YR3070D	53	9	12,5	22	Ø16	Ø22	17	75	110	170	Ø67	70	24	43	78	84	14,5	26,5	46,5	G1/8	M12x1,75

	X	Y	Z	AA	BB	CC	DD	EE	FF	GG	HH	II	LL	MM	NN	OO	PP	QQ	RR	SS	TT
YR3010D	12	4	2,7	2,5	27	M4x0,8	8	M5x0,8	15	2	3	3,5	27,1	19	6	Ø20	Ø45	Ø46	Ø6,8	Ø11	6,5
YR3020D	15	6,5	3,2	2,5	34	M6x1	10	M6x1	20,5	2	4	5	27,1	19	8	Ø28	Ø60	Ø61	Ø8,6	Ø14	8,5
YR3030D	15	4,5	3,7	3	37	M6x1	10	M6x1	23	2	4	4,5	27,1	19	8	Ø32	Ø65	Ø67	Ø8,6	Ø14	8,5
YR3050D	18	5	4,2	2	50	M8x1,25	10	M8x1,25	26,5	2	5	5,5	27,1	19	10	Ø35	Ø75	Ø77	Ø10,5	Ø17	10,5
YR3070D	18	5	4,2	4	57	M8x1,25	10	M8x1,25	32,5	2	5	3,5	32	-	10	Ø46	Ø88	Ø90	Ø10,5	Ø17	10,5

YR3 Ø 32 ÷ 63

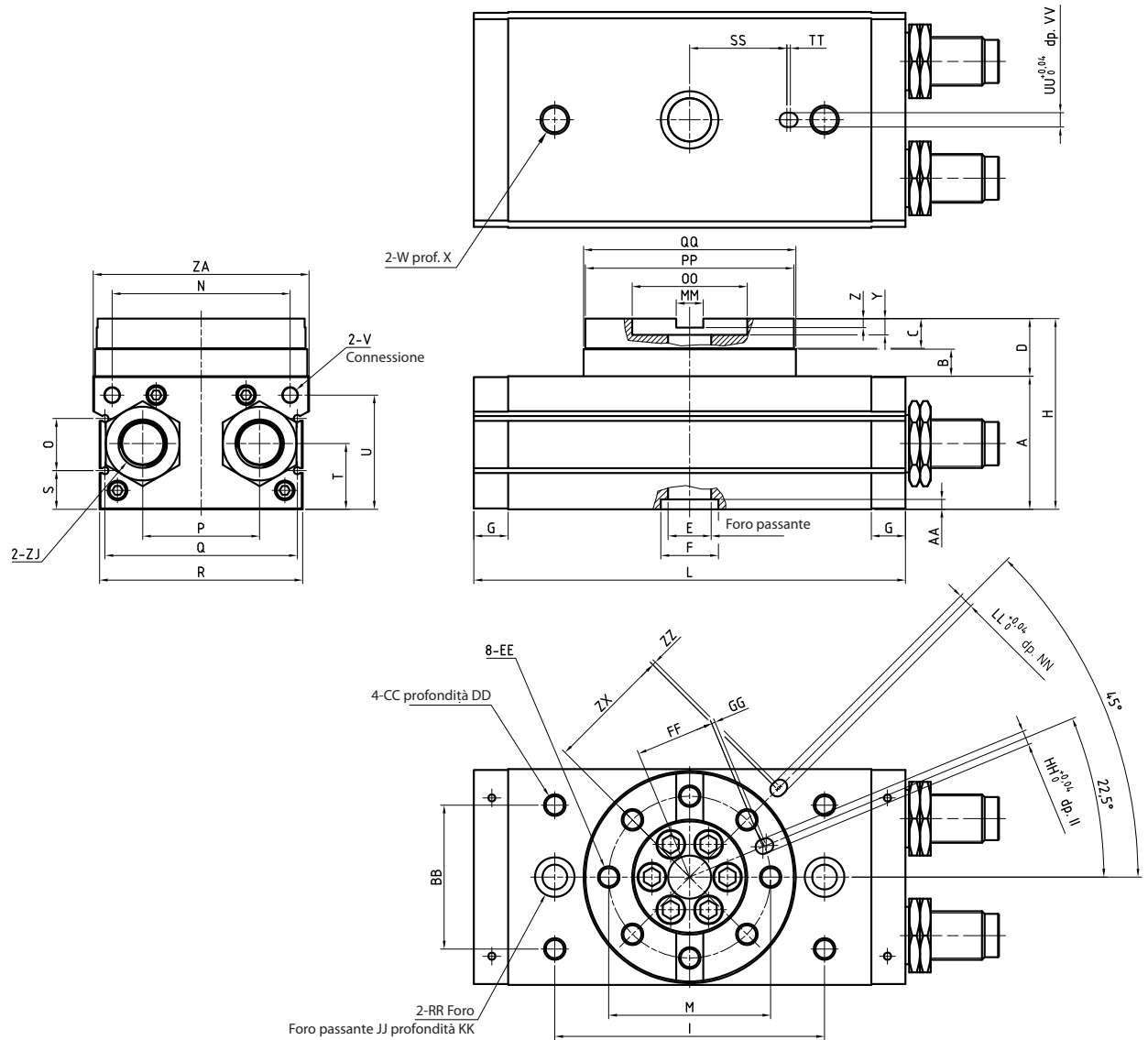

	A	B	C	D	E	F	G	H	I	L	M	N	O	P	Q	R	S	T	U	V	W	X	Y	Z
YR3100D	59	12	14,5	27	Ø19	Ø24	14	86	130	189	77	82	27	50	89	95	16	29,5	50,3	G1/8	M12x1,75	18	6	5
YR3200D	74	15	16,5	32	Ø24	Ø32	19	106	150	240	90	99	29	65	107	113	21,5	36,5	63,5	G1/8	M16x2	25	9	5
YR3300D	83,5	16	19,5	36,5	Ø26	Ø36	25	120	180	280	100	115	34	77	130	136	24,5	41,5	73,5	G1/4	M20x2,5	25	10	8
YR3500D	95	17	22	40	Ø26	Ø36	25	135	220	320	120	129	38	85	150	156	28	47	84	G1/4	M20x2,5	25	12	8

	AA	BB	CC	DD	EE	FF	GG	HH	II	JJ	KK	LL	MM	NN	OO	PP	QQ
YR3100D	4	66	M8x1,25	10	M10x1,5	37,5	2	6	4,5	17	10,5	6	12	4,5	Ø56	Ø98	Ø100
YR3200D	5,5	80	M12x1,75	13	M12x1,75	44	2	8	4,5	22	14,5	8	15	4	Ø64	Ø116	Ø118
YR3300D	5,5	88	M12x1,75	13	M16x2	49	2	8	4,5	26	16,5	8	18	4	Ø70	Ø132	Ø133
YR3500D	5,5	100	M12x1,75	13	M16x2	59	2	10	5,5	26	16,5	10	18	4,5	Ø85	Ø150	Ø152

	RR	SS	TT	UU	VV	ZA	ZX	ZJ	ZZ
YR3100D	Ø10,5	-	-	-	-	102	59	M20x1,5	2
YR3200D	Ø14,2	54	2	8	6,5	120	69	M27x1,5	2
YR3300D	Ø17,5	69	2	8	6,5	-	75	M27x1,5	2
YR3500D	Ø17,5	80	2	10	6,5	-	88	M27x1,5	2