

G-6

20 mm Valves and Solenoid Valves - Threaded body G1/8

- G1/8 threaded valve body with traditional Univer spool system
- Version with integrated electrical connection and external connection
- Compact design
- High flow rate
- Versions available: 5/2 - 5/3 - 3/2+3/2

Available ATEX version upon request

CE Ex II 2Gc IIC T5 II 2Dc T100°C

CE Ex II 3 GD c nA II T5-10°C ≤ Ta ≤ 45°C

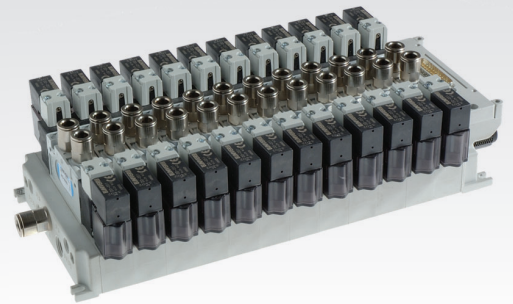

TECHNICAL CHARACTERISTICS

Ambient temperature	-5 ÷ +50 °C
Fluid temperature	Max +50 °C
Fluid	50 µm filtered air, with or without lubrication
Commutation system	spool
Ways/Positions	5/2, 5/3, 3/2+3/2
Pressure	1,5 ÷ 9 bar
Control	indirect electro-pneumatic, pneumatic
Return	mechanical spring, pneumomechanical spring
Connections	G1/8
Nominal Ø	5 mm
Nominal flow rate (NI/min)	5/2 = 770 5/3 = 700 3/2+3/2 = 670

CONSTRUCTIVE CHARACTERISTICS

Valve body	zamak
Seals	nitrile rubber
Subbase and actuators	self-extinguishing technopolymer
Spool	aluminum

ELECTRIC CHARACTERISTICS

Electropilot/coil	A series/U05 - B series/U04
Voltage	24 V DC - 12 V DC - 24 V AC - 110 V AC - 230 V AC (only for version with integrated electrical connection)
Power consumption	U05 = 2 W (DC) 2,3 VA (AC) U04 = 1,2 W (DC)
Protection degree	IP65
Manual override	recessed button - 1 position

CODIFICATION KEY

G	-	6	6	4	4		
1		2	3	4	5	6	

1 Series	2 Type	3 Control 14	4 Return 12
G-6 = 20 mm Valves and solenoid valves - threaded body G1/8	2 = 5/2 3 = 5/3 c.c. 4 = 5/3 o.c. 5 = 5/3 p.c. 6 = 3/2+3/2 NC-NC 7 = 3/2+3/2 NC-NO 8 = 3/2+3/2 NO-NO	3 = Pneumatic amplified 4 = Electrical amplified DC 5 = Electrical amplified DC/AC 6 = Electrical amplified DC (B series 10mm electropilot)	0 = Pneumomechanical spring 1 = Mechanical spring 3 = Pneumatic amplified 4 = Electrical amplified DC 5 = Electrical amplified DC/AC 6 = Electrical amplified DC (B series 10 mm electropilot)

5 Option	6 ATEX version
D = External servoassisted pilot	X = Atex (upon request)

See ATEX Catalogue for types and versions

o.c. = open centres c.c. = closed centres p.c. = pressurized centres

Subject to change

Single electric impulse

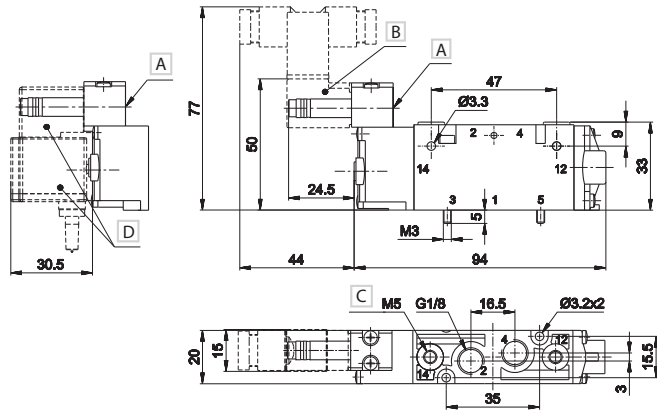
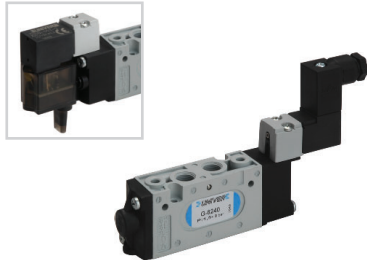

- A Manual override
- B Coil with connector for single connection
- C External servoassisted pilot
- D Coil with integrated connector for multipolar version DD-051-2C/DD-040-2C

1 = Supply port
 2 - 4 = Use
 3 - 5 = Exhaust
 14 = Control
 12 = Return

	Symbol	Control	Return	Flow rate (NI/min)	Pressure bar	Resp. Time (ms)		Weight Kg	Part no.
						En.	De-en.		
5/2		electrical amplified	pneumomechanical spring	770	1,5÷9	21	30	0,112	G-6240 G-6250
5/2		electrical amplified	mechanical spring	770	1,5÷9	18	64	0,112	G-6241 G-6251

Double electric impulse

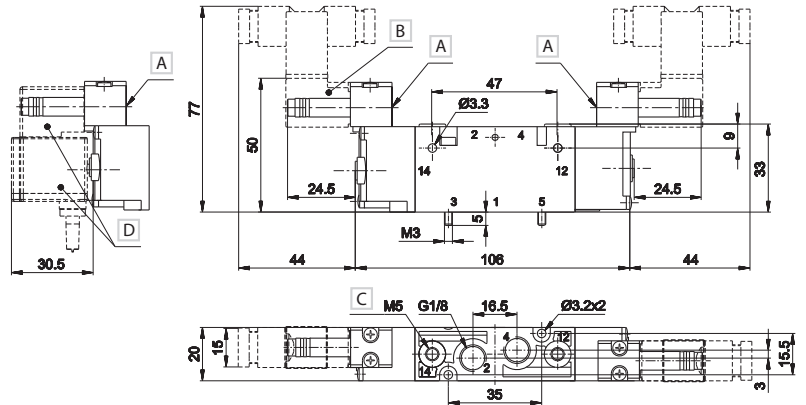
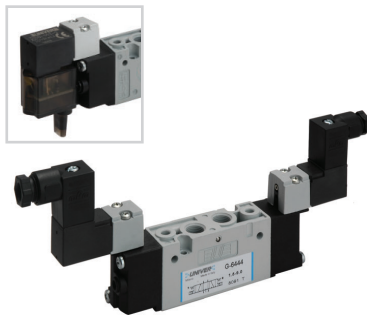

- A Manual override
- B Coil with connector for single connection
- C External servoassisted pilot
- D Coil with integrated connector for multipolar version DD-051-2C/DD-040-2C

1 = Supply port
 2 - 4 = Use
 3 - 5 = Exhaust
 14 = Control
 12 = Return

	Symbol	Control	Return	Flow rate (NI/min)	Pressure bar	Resp. Time (ms)		Weight Kg	Part no.
						En.	De-en.		
5/2		electrical amplified	electrical amplified	770	0,6÷9	16	16	0,143	G-6244 G-6255
5/3 c.c.		electrical amplified	electrical amplified	700	1,9÷9	16	47	0,148	G-6344 G-6355
5/3 o.c.		electrical amplified	electrical amplified	700	2,0÷9	16	47	0,148	G-6444 G-6455
5/3 p.c.		electrical amplified	electrical amplified	700	1,9÷9	16	47	0,148	G-6544 G-6555
3/2 NC + 3/2 NC		electrical amplified	electrical amplified	670	1,5÷9	14	17	0,140	G-6644 G-6655
3/2 NC + 3/2 NO		electrical amplified	electrical amplified	670	1,5÷9	14	17	0,140	G-6744 G-6755
3/2 NO + 3/2 NO		electrical amplified	electrical amplified	670	1,5÷9	14	17	0,140	G-6844 G-6855

o.c. = open centres c.c. = closed centres p.c. = pressurized centres
 Solenoid valves are supplied without coil and connector

Single electric impulse

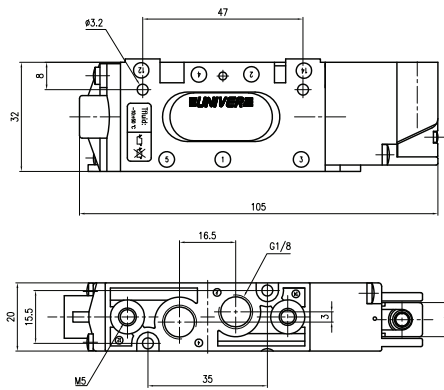

- A Manual override
- B Coil with connector for single connection
- C External servoassisted pilot

1 = Supply port
2 - 4 = Use
3 - 5 = Exhaust
14 = Control
12 = Return

Symbol	Control	Return	Flow rate (NI/min)	Pressure bar	Resp. Time (ms)		Weight Kg	Part no.
					En.	De-en.		
5/2	14 electrical amplified	12 pneumomechanical spring	770	1,5÷9	21	30	0,112	G-6260 G-6261

Double electric impulse

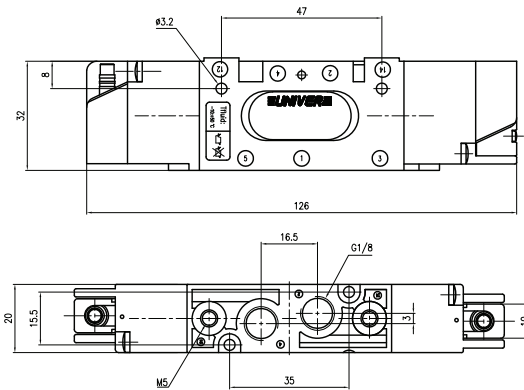

- A Manual override
- B Coil with connector for single connection
- C External servoassisted pilot

1 = Supply port
2 - 4 = Use
3 - 5 = Exhaust
14 = Control
12 = Return

Symbol	Control	Return	Flow rate (NI/min)	Pressure bar	Resp. Time (ms)		Weight Kg	Part no.
					En.	De-en.		
5/2	14 electrical amplified	12 electrical amplified	770	0,6÷9	16	16	0,143	G-6266
5/3 c.c.	14 electrical amplified	12 electrical amplified	700	1,9÷9	16	47	0,148	G-6366
5/3 o.c.	14 electrical amplified	12 electrical amplified	700	2,0÷9	16	47	0,148	G-6466
5/3 p.c.	14 electrical amplified	12 electrical amplified	700	1,9÷9	16	47	0,148	G-6566
3/2 NC + 3/2 NC	14 electrical amplified	12 electrical amplified	670	1,5÷9	14	17	0,140	G-6666
3/2 NC + 3/2 NO	14 electrical amplified	12 electrical amplified	670	1,5÷9	14	17	0,140	G-6766
3/2 NO + 3/2 NO	14 electrical amplified	12 electrical amplified	670	1,5÷9	14	17	0,140	G-6866

o.c. = open centres c.c. = closed centres p.c. = pressurized centres
Solenoid valves are supplied without coil and connector

Single pneumatic impulse

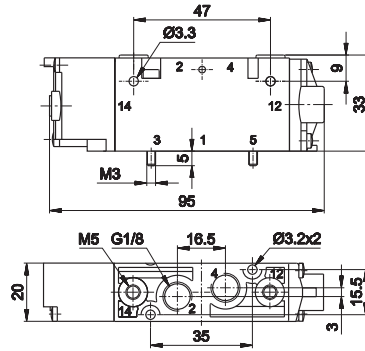

1 = Supply port
2 - 4 = Use
3 - 5 = Exhaust
14 = Control
12 = Return

	Symbol	Control	Return	Flow rate (NI/min)	Pressure bar	Resp. Time (ms)		Weight Kg	Part no.
						En.	De-en.		
5/2		pneumatic amplified	pneumomechanical spring	770	1,5÷10	7	16	0,092	G-6230
5/2		pneumatic amplified	mechanical spring	770	1,5÷10	6	18	0,092	G-6231

Double pneumatic impulse

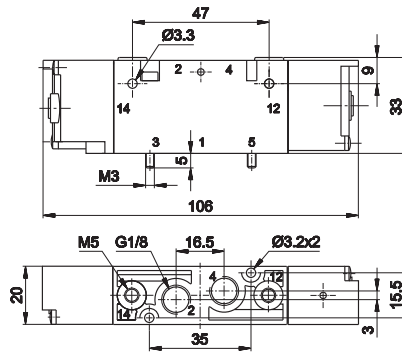

1 = Supply port
2 - 4 = Use
3 - 5 = Exhaust
14 = Control
12 = Return

	Symbol	Control	Return	Flow rate (NI/min)	Pressure bar	Resp. Time (ms)		Weight Kg	Part no.
						En.	De-en.		
5/2		pneumatic amplified	pneumatic amplified	770	0,7÷10	5	5	0,103	G-6233
5/3 c.c.		pneumatic amplified	pneumatic amplified	700	1,9÷9	6	19	0,192	G-6333
5/3 o.c.		pneumatic amplified	pneumatic amplified	700	2,0÷9	6	19	0,192	G-6433
5/3 p.c.		pneumatic amplified	pneumatic amplified	700	1,9÷9	6	19	0,192	G-6533
3/2 NC + 3/2 NC		pneumatic amplified	pneumatic amplified	670	1,5÷9	3	14	0,188	G-6633
3/2 NC + 3/2 NO		pneumatic amplified	pneumatic amplified	670	1,5÷9	3	14	0,188	G-6733
3/2 NO + 3/2 NO		pneumatic amplified	pneumatic amplified	670	1,5÷9	3	14	0,188	G-6833

o.c. = open centres c.c. = closed centres p.c. = pressurized centres

3

Multipin electrical connection

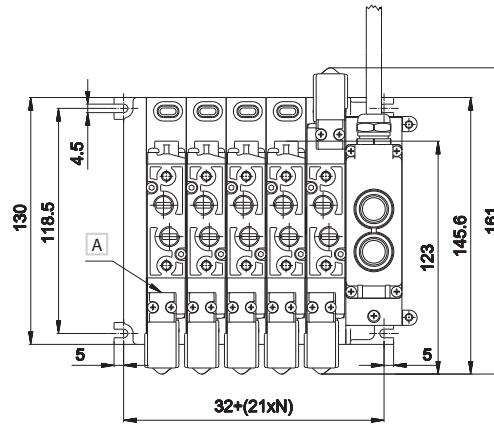
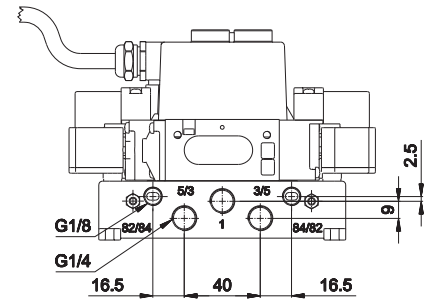
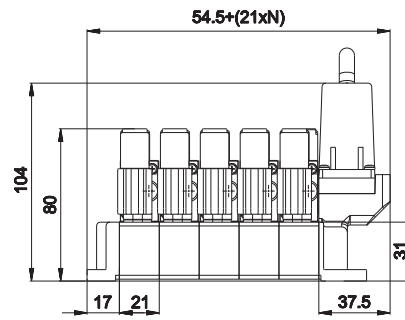

A Manual override

1 = Supply port
 5/3 - 3/5 = Exhaust G1/4
 82/84 - 84/82 = Electropilot exhaust G1/8
 N = Number of valve positions

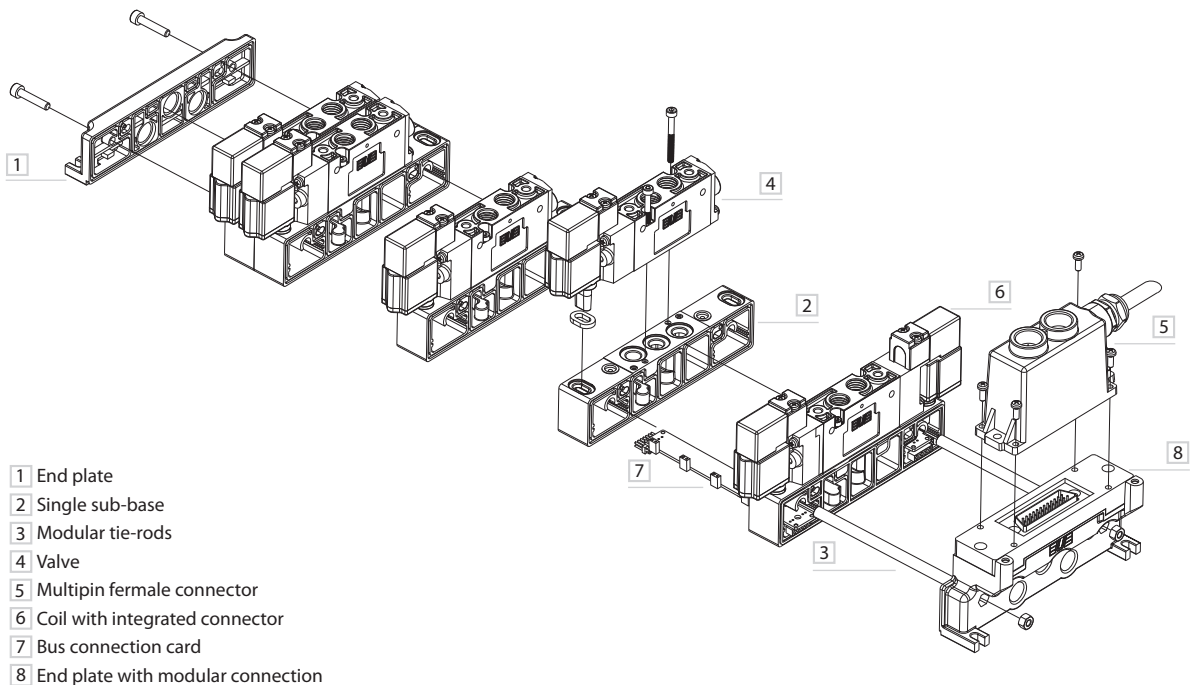

- 1 End plate
- 2 Single sub-base
- 3 Modular tie-rods
- 4 Valve
- 5 Multipin female connector
- 6 Coil with integrated connector
- 7 Bus connection card
- 8 End plate with modular connection

Tightening torque for fittings

Thread	Max torque (Nm)
M5	3
M7	3
G1/8	3
G1/4	10

Electrical connection with external connector

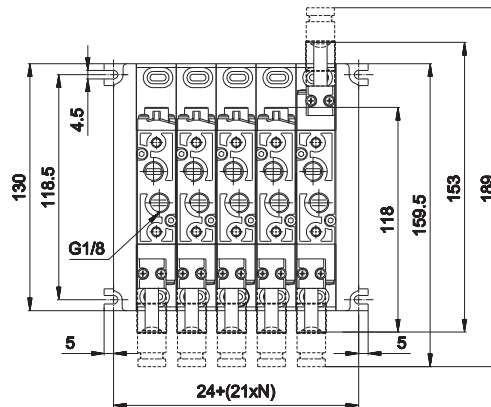
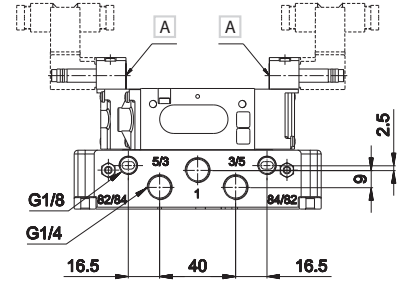
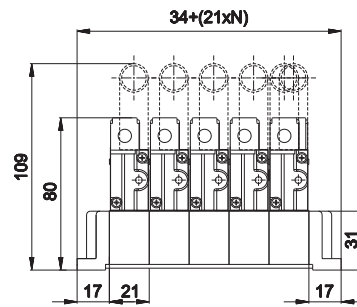

A Manual override

- 1 = Supply port
- 5/3 - 3/5 = Exhaust G1/4
- 82/84 - 84/82 = Electropilot exhaust G1/8
- N = Number of valve positions

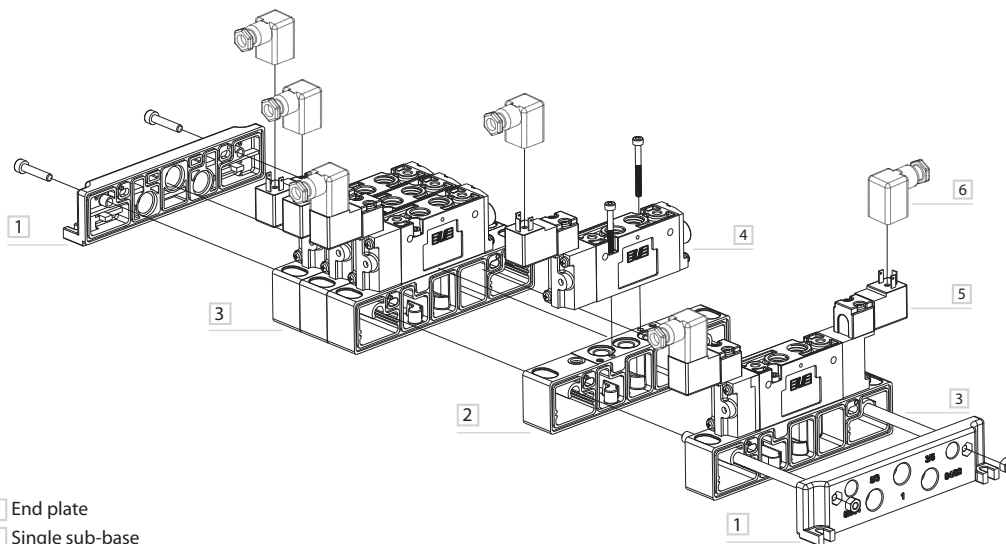

- 1 End plate
- 2 Single sub-base
- 3 Modular tie-rods
- 4 Valve
- 5 Coil
- 6 Single connector

Tightening torque for fittings

Thread	Max torque (Nm)
M5	3
M7	3
G1/8	3
G1/4	10

Electrical connection with loose cables

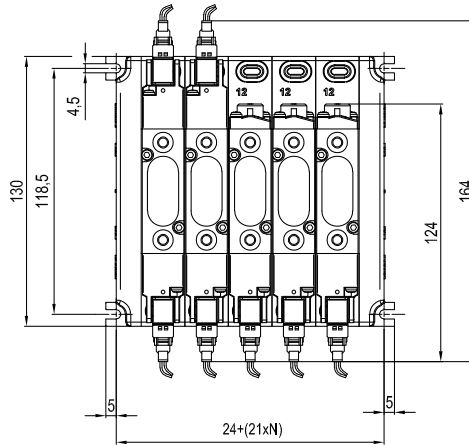
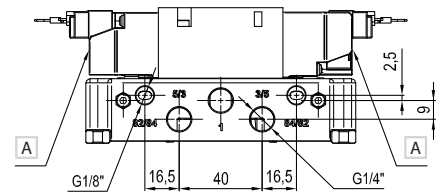
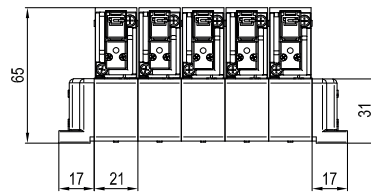
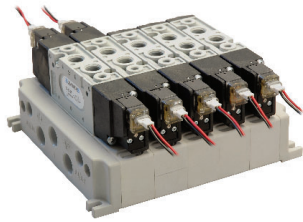

A Manual override

1 = Supply port
 5/3 - 3/5 = Exhaust G1/4
 82/84 - 84/82 = Electropilot exhaust G1/8
 N = Number of valve positions

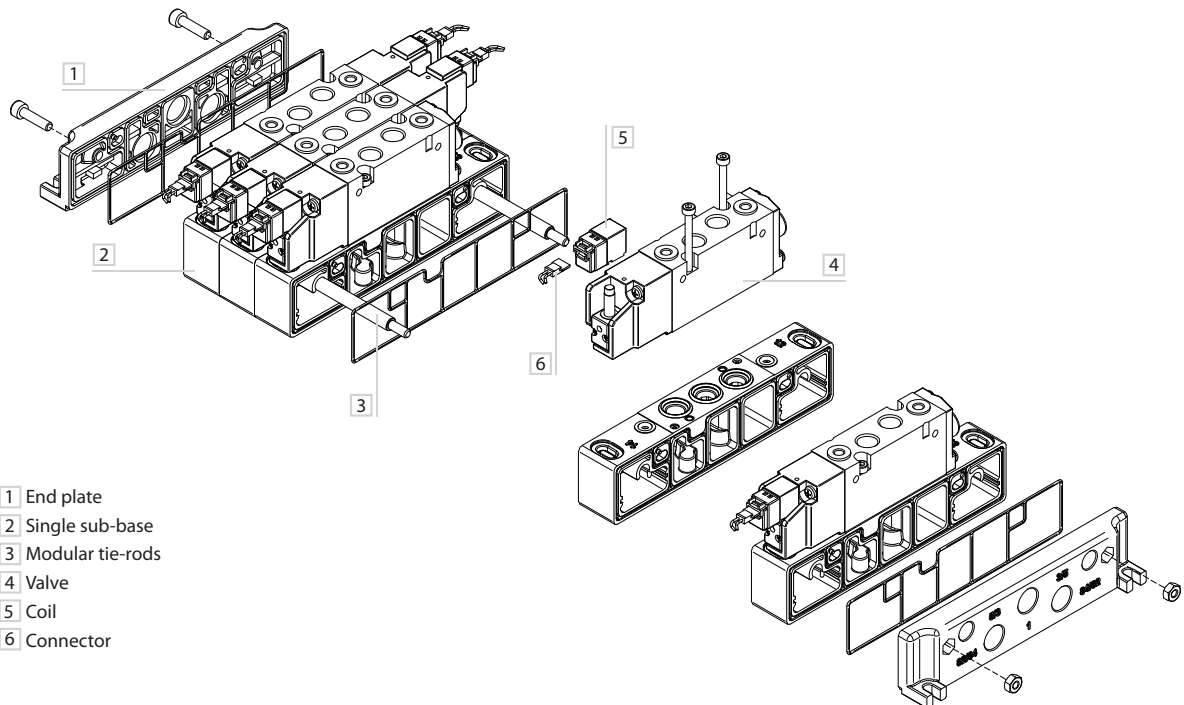

- 1 End plate
- 2 Single sub-base
- 3 Modular tie-rods
- 4 Valve
- 5 Coil
- 6 Connector

Tightening torque for fittings

Thread	Max torque (Nm)
M5	3
M7	3
G1/8	3
G1/4	10

GP-6100 GP-6110 GP-611212 GP-611806 GP-6310/1/2 GP-6320/1/2

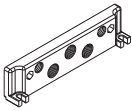

threaded end plate
weight: 0,046 Kg

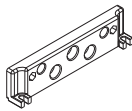

blank end plate
weight: 0,050 Kg

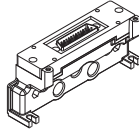

threaded end plate with male connector
25 poles 12+12 coils
control 12-14
weight: 0,100 Kg

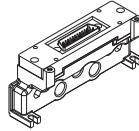

threaded end plate with male connector
25 poles
18 coils control 14
6 coils control 12
(only for control 14
more than 12 coils max 18)
weight: 0,102 Kg

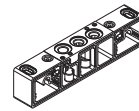

sub-base with open diaphragms
GP-6310 without electrical connection
GP-6311 monostable
GP-6312 bistable
weight: 0,060 Kg

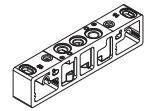

sub-base with closed diaphragms
GP-6320 without electrical connection
GP-6321 monostable
GP-6322 bistable
weight: 0,062 Kg

GP-6330/1/2 GP-6340/1/2 GP-6380 GP-6385

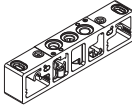

3 1 5
sub-base with closed supply and open exhausts
GP-6330 without electrical connection
GP-6331 mostable
GP-6332 bistable
weight: 0,062 Kg

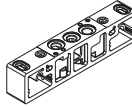

3 1 5
sub-base with open supply and closed exhausts
GP-6340 without electrical connection
GP-6341 mostable
GP-6342 bistable
weight: 0,062 Kg



intermediate supply plate
(to be used only with GP-63... series sub-base)
weight: 0,036 Kg



closing plate for unused station
weight: 0,018 Kg

GP-6400-1 GP-6400-2 GP-6400-5 GP-6512-01/..MF GP-6514-01/..MF GP-651418



3
modular tie-rod
1 valve place
weight: 0,004 Kg
(package 100 pcs.)



modular tie-rod
2 valve places
weight: 0,010 Kg
(package 100 pcs.)

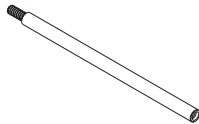

modular tie-rod
5 valve places
weight: 0,022 Kg
(package 100 pcs.)



BUS connection card
control side 12 with 12 pin
GP-6512-01MF 1 place
GP-6512-02MF 2 places
GP-6512-03MF 3 places
GP-6512-05MF 5 places
GP-6512-06MF 6 places
weight: 0,003 Kg
(for each place)



BUS connection card
control side 14 with 12 pin
GP-6514-01MF 1 place
GP-6514-02MF 2 places
GP-6514-03MF 3 places
GP-6514-05MF 5 places
GP-6514-06MF 6 places
weight: 0,003 Kg
(for each place)

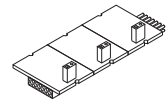

BUS connection card
control side 14 with 18 pins
(only 12 places)
for manifolds with control 14 and more than 12 coils up to 18 coils use GP-651418 card 12 places and then GP-6514...
weight: 0,003 Kg
(for each place)

AZ4-VN0416 screw M04x16 for tie-rods (package 100 pcs.)
AZ4-SN004A hexagonal nut M4 (package 100 pcs.)

upon request customized solutions up to 12 places

DD-... DD-051-2C/DD-040-2C DE-652I D-530-30/50/200



24 V CC 2 W coil
for single connection
weight: 0,019 Kg

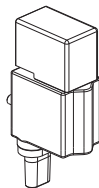

24 V CC 2 W coil with integrated connector
for multipin version
weight: 0,028 Kg

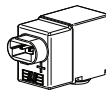

24 V DC 1,35 W coil with in-line connector with protection for a complete tightness
weight: 0,013 Kg

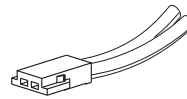

Miniature connector with loose cables

D-530-30 = wire length 300 mm
D-530-50 = wire length 500 mm
D-530-200 = wire length 2000 mm

Electrical connections

AM-5109

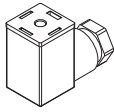

■ 15 mm connector

TSCF24S0300
TSCF24S0500
TSCF24S1000

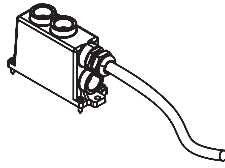

■ flying female connector sub D according to CEI 20-22 O.R. II (upon request) prewired for 24 coils M3 x 12 fixing screws

Colour identification according to standard DIN 47100

Female connector D-SUB 25 poles for 12+12 coils

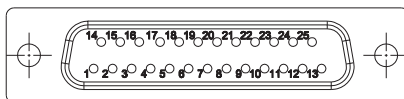

PIN No.	Colour	Coil	Control side		Valve No.
			GP-611212	GP-611806	
1	white	1	14	14	1
2	brown	2	12	12	1
3	green	3	14	14	2
4	yellow	4	12	12	2
5	grey	5	14	14	3
6	pink	6	12	12	3
7	blue	7	14	14	4
8	red	8	12	12	4
9	black	9	14	14	5
10	violet	10	12	12	5
11	grey-pink	11	14	14	6
12	red-blue	12	12	12	6
13	white-green	13	14	14	7
14	brown-green	14	12	14	7
15	white-yellow	15	14	14	8
16	yellow-brown	16	12	14	8
17	white-grey	17	14	14	9
18	grey-brown	18	12	14	9
19	white-pink	19	14	14	10
20	pink-brown	20	12	14	10
21	white-blue	21	14	14	11
22	brown-blue	22	12	14	11
23	white-red	23	14	14	12
24	brown-red brown-black shield	common low	-	-	-
25	white-black	24	12	14	12