

ULP 50

Pneumatic retractable locating pin unit, single rod, Ø50 mm

Pneumatic retractable pin unit, single rod, typically used in welding applications to locate metal sheets in a definite position.

- Metal rod scraper
- Antirotation system
- Double guide to avoid backlash
- Compact dimensions
- Electronic or pneumatic sensor
- Many rod end styles available
- Version with hand lever available (ULM series)

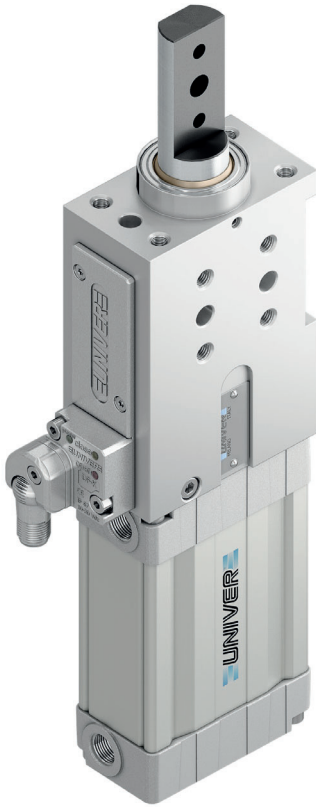

3

CHARACTERISTICS

Operating temperature	5° ÷ 45° C
Min./Max. operating pressure	0,4 / 0,6 MPa
Bore Ø	50 mm
Max Pull force (0,5 MPa)	860 N
Max Push force (0,5 MPa)	960 N
Max. Torque (6 Nm)	± 0,06 mm
Max. Deflection (7,5 Nm)	± 0,03 mm
Weight	2,3 Kg
Pneumatic supply ports	G 1/4 on both sides
Sensor	electronic (optical)
Supply voltage	10 ÷ 30 Vdc
IP code	IP 65

CODIFICATION KEY

UL | P | 50 | 040 | C | X | K | 0 | |

1 2 3 4 5 6 7 8 9



LIGHTWEIGHT



METAL SCRAPER



OPTICAL SENSOR



DOUBLE GUIDE



ANTI ROTATION



COMPACT

1 SERIES
UL = UNICLAMP locating pin unit

2 VERSION
P = Pneumatic, single rod

3 SIZE
50 = Ø50 mm

4 STROKE
015 = 15 mm 060 = 60 mm
025 = 25 mm 075* = 75 mm
040 = 40 mm 100* = 100 mm
050 = 50 mm 110* = 110 mm
*special strokes oversized body

5 ROD END STYLE
A = Rod for offset pins
B = Rod with profiled end
C = Rod with cross-profiled end inner Ø 16 mm
D = Rod for offset pins with oversized dowel holes
E = Rod with cross profiled end inner Ø 10 mm
F = Compatible with NAAMS, inner Ø 16
H = Rod with flat end, inner Ø10 mm
I = Rod with flat end, inner Ø12 mm
L* = Rod with inner Ø12 mm
M* = Rod with inner Ø 20 mm
*compatible with CNOMO standard

6 ROD ORIENTATION
X = Symmetrical

E* = East

O* = West

N* = North

S* = South

*only with "A" and "D" rod style

7 SENSOR
N = No sensor (with protection plate)
K = Electronic sensor PNP, M12 (DF-K)
D = Pneumatic sensor (DF-UPNW)
J = Electronic sensor NPN, optical (DF-J)
Y = Electronic sensor PNP, M12 (DF-Y) white LED

8 PRODUCT REVISION
Assigned by UNIVER

9 ATEX
X = ATEX option
See ATEX Catalogue for types and versions

A Rod for offset pins

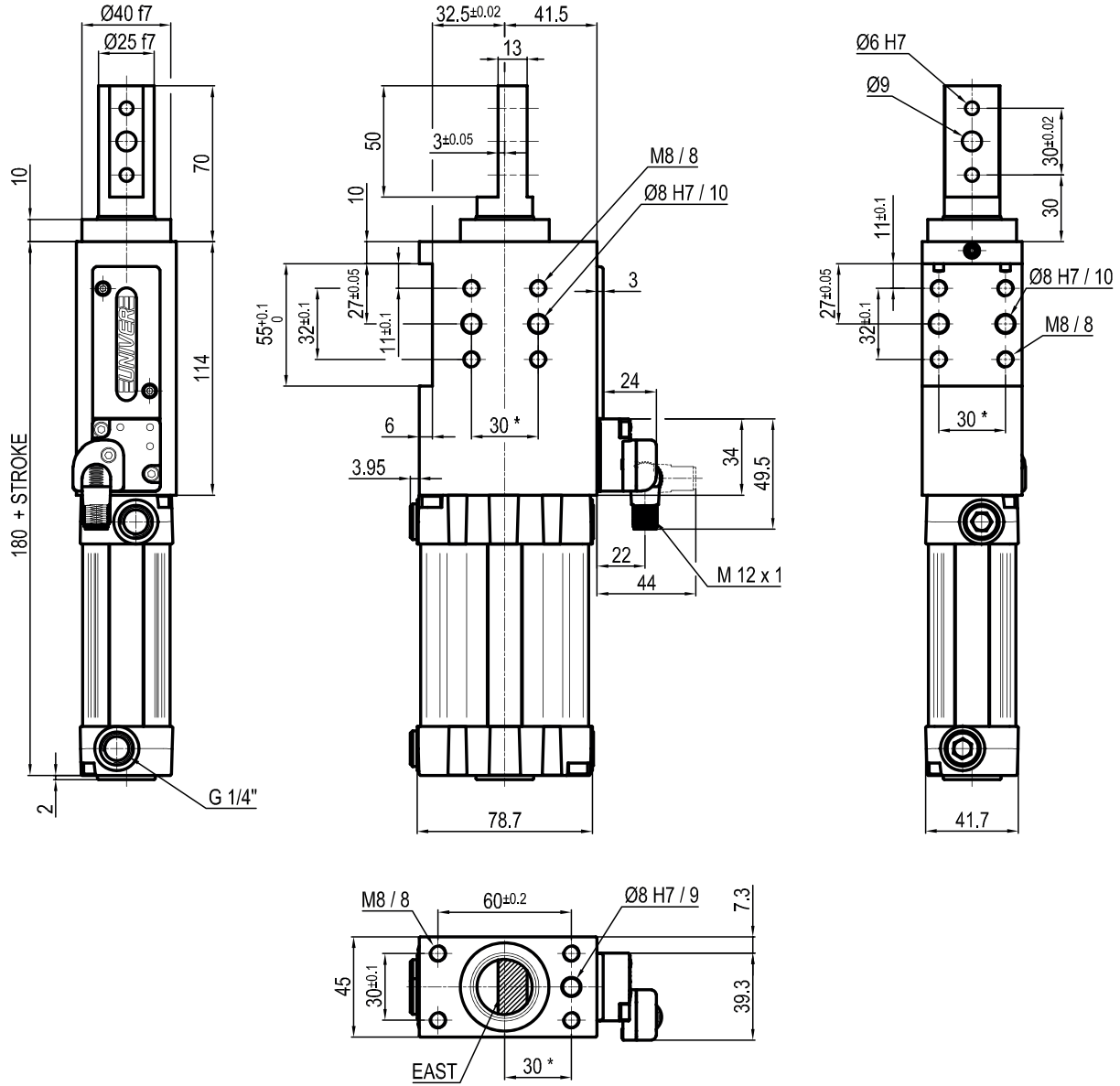

3

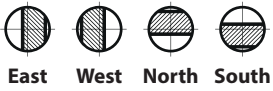

*TOLERANCE BETWEEN DOWELS ± 0,02 BETWEEN SCREW HOLES ± 0,1

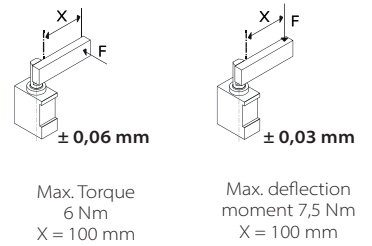

Sensors



Electronic (optical)

- DF-K PNP M12
- DF-J NPN M12
- DF-Y PNP M12 White LED



Pneumatic

DF-UPNW

B Rod with profiled end

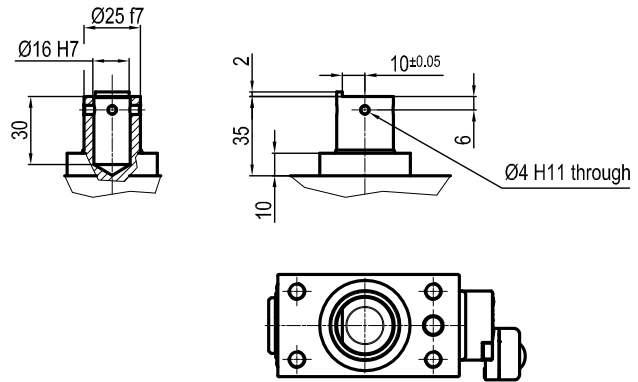

C Rod with cross-profiled end
Inner Ø16 mm

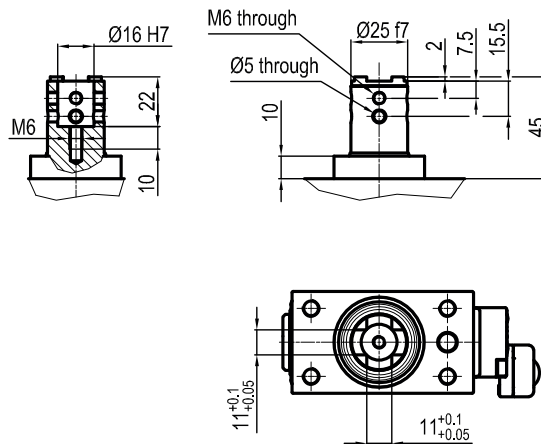

D Rod for offset pins
Oversized dowel holes

Max. deflection moment 5,5 Nm
X = 100 mm

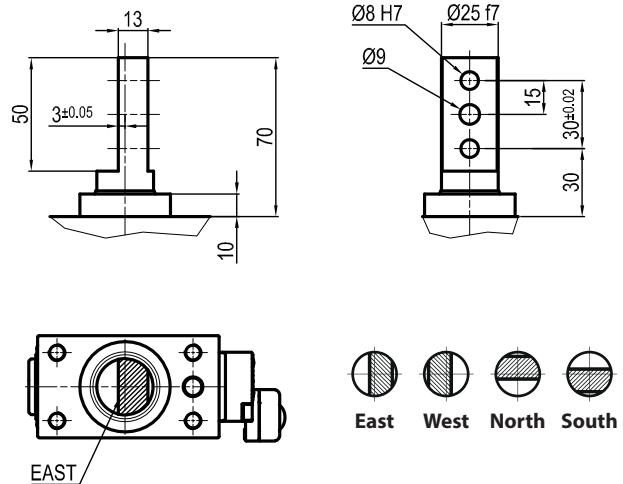

E Rod with cross-profiled end
Inner Ø10 mm

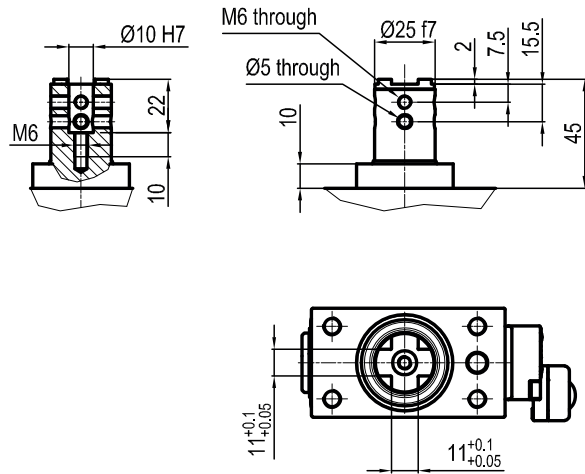

F Compatible with NAAMS
Inner Ø16 mm

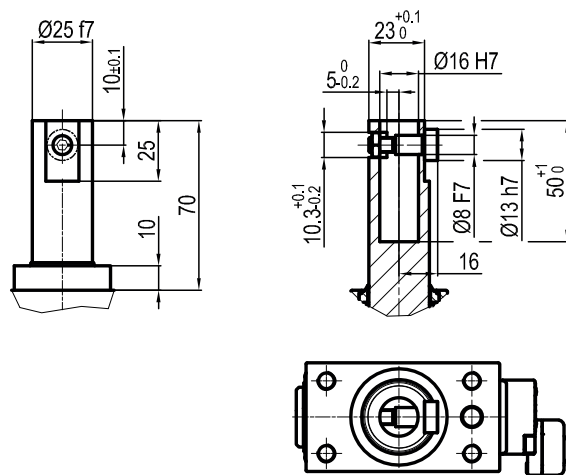

H Rod with flat end
Inner Ø10 mm

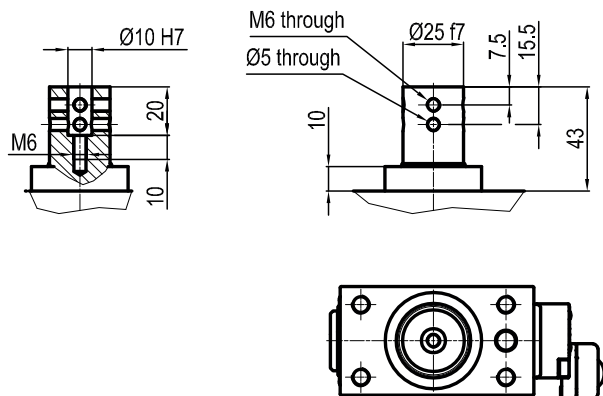

I Rod with flat end
Inner Ø12 mm

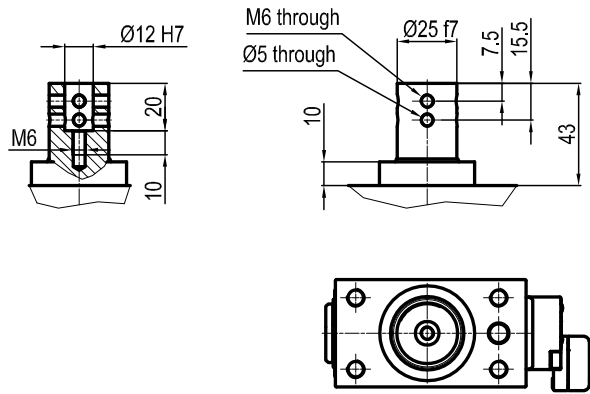

L Rod compatible with CNOMO standard
Inner Ø12 mm

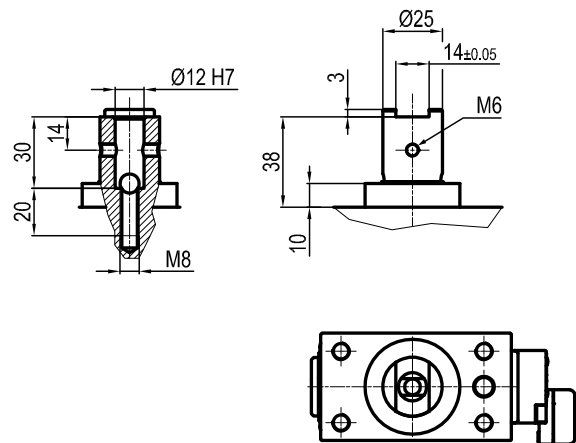

M Rod compatible with CNOMO standard
Inner Ø20 mm

