

UCBP 63

Pneumatic power clamps Ø63 mm

Pneumatic power clamps with compensation system, toggle-joint mechanism and stepless adjustable opening angle, typically used for handling and holding metal sheets in welding applications

- Lightweight aluminium construction
- Compact dimensions
- Integrated compensation system up to 2,7 mm
- Version with hand lever available
- Fully optical electronic sensor or pneumatic sensor
- Fixing pattern on 4 sides
- Manual unlocking in case of air loss
- Self-holding system for open position available
- Clamping arm in aluminium or steel

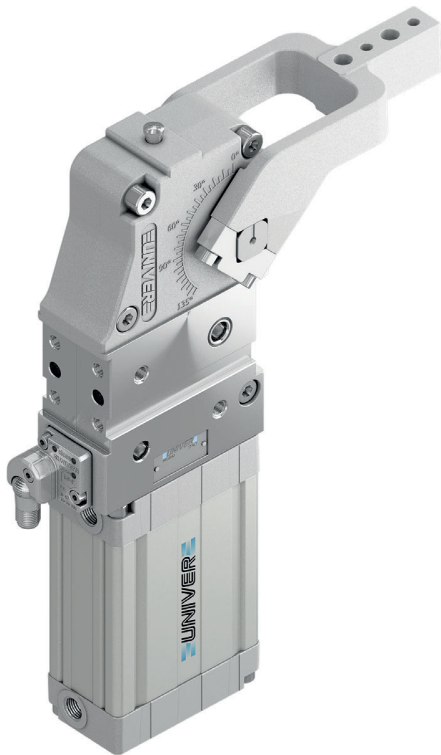

CHARACTERISTICS

Operating temperature	5° ÷ 45° C
Min./Max. Operating pressure	0,4 / 0,6 MPa
Opening angle*	0° ÷ 135°
Bore Ø	63 mm
Holding moment	1750 Nm
Clamping moment (0,5 MPa)	420 Nm
Weight (clamping arm not included)	2,9 Kg
Pneumatic supply ports	G1/4 on both sides
Sensor	electronic (optical)
Supply voltage	10 ÷ 30 Vdc
IP code	IP65

*The opening angle range may vary according to the arm position and style.

CODIFICATION KEY

UC	B	P	63	O	E	A	K	0	
1	2	3	4	5	6	7	8	9	10

- COMPENSATION
- LIGHTWEIGHT
- IRREVERSIBLE
- ANGLE ADJUSTMENT
- OPTICAL SENSOR
- COMPACT

1 SERIES UC = UNICLAMP Power clamps	6 ARM STYLE C = Central, 15 mm offset D = Right, 15 mm offset S = Left, 15 mm offset E = Central, 45 mm offset F = Right, 45 mm offset L = Left, 45 mm offset N = No arm For other versions contact our Sales Dept.
2 STANDARD B = European standard	7 ARM TYPE A = Aluminium S = Steel N = No arm
3 VERSION P = Pneumatic	8 SENSOR N = No sensor (with protection plate) K = Electronic sensor PNP, M12 (DF-K) D = Pneumatic sensor (DF-UPNW) J = Electronic sensor NPN, optical (DF-J) Y = Electronic sensor PNP, M12 (DF-Y) white LED
4 SIZE 63 = Ø63 mm	9 PRODUCT REVISION Assigned by UNIVER
5 ARM POSITION V = 90°	10 ATEX X = ATEX option See ATEX Catalogue for types and versions
O = 180°	
N = No arm	

2

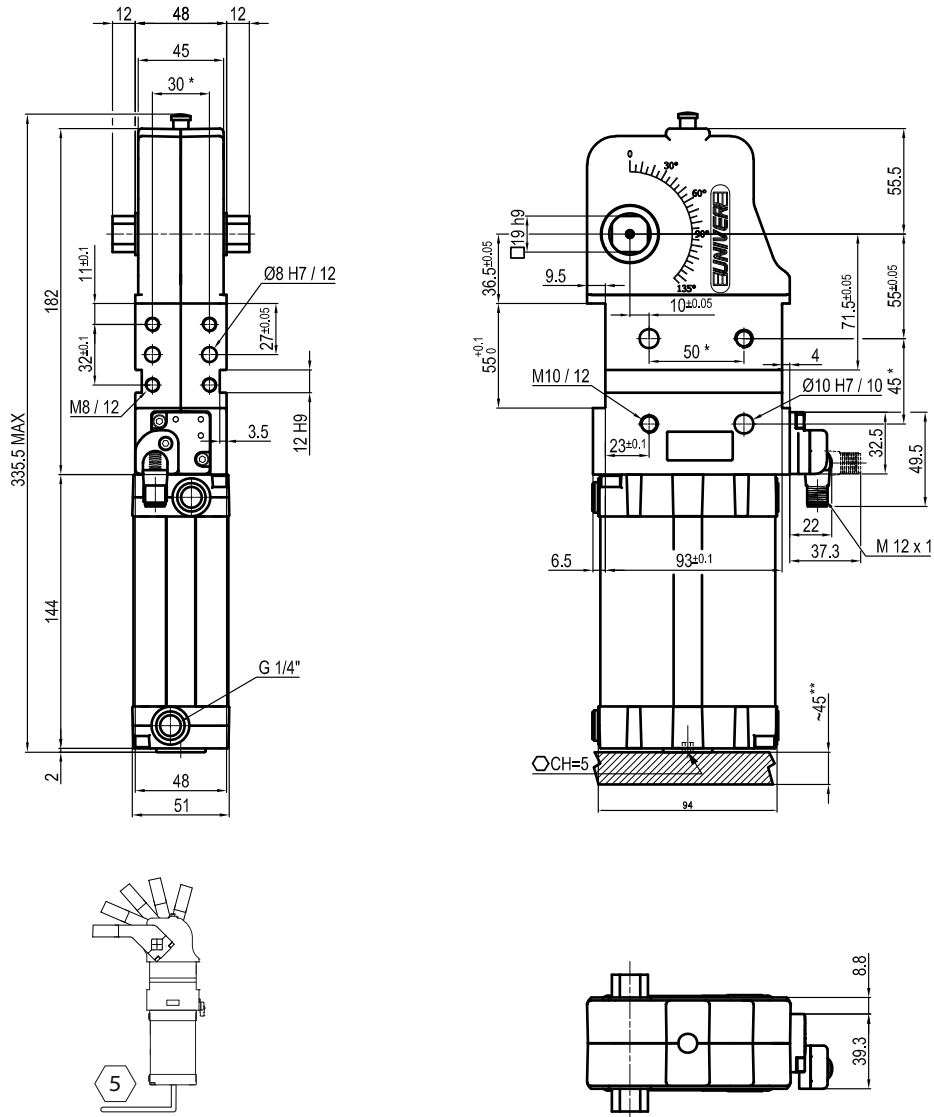

* TOLERANCE BETWEEN DOWELS ± 0,02, BETWEEN SCREW HOLES ± 0,1
 ** AREA TO ACCESS ANGLE ADJUSTMENT

Maximum Applicable Load

Pressure: 5 bar - 90° cycle time (Open - Close)

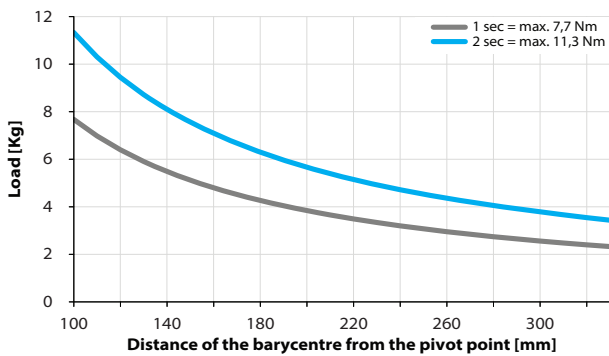

Air Consumption per Cycle

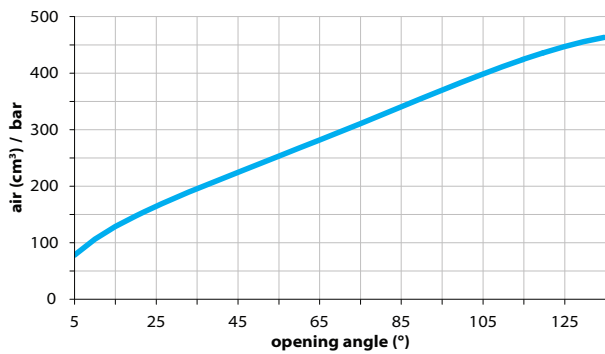

Clamping Arms

Arm Offset 15mm

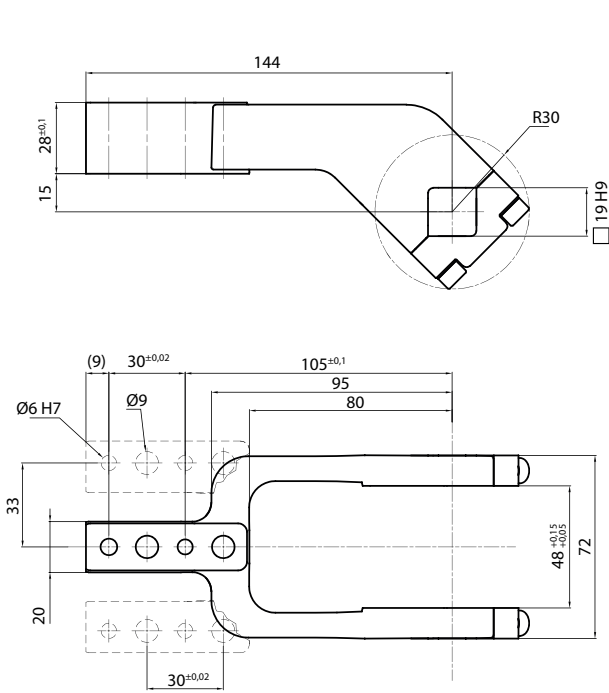

Arm Offset 45mm

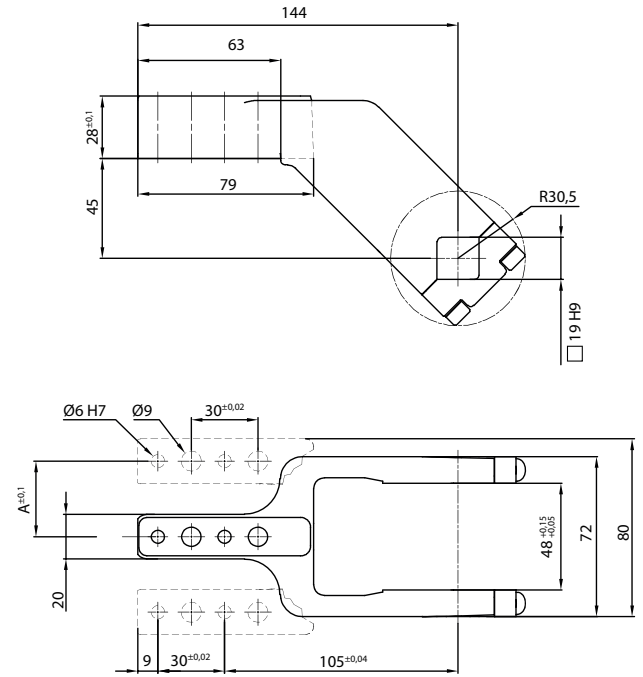

Armcode	Offset	Material	Arm style	Weight (Kg)	Opening angle (90°)	Opening angle (180°)
LKP00CL	15	ALUMINIUM	CENTRAL	0,4	0÷135°	0÷105°
LKP00DL	15	ALUMINIUM	RIGHT	0,4	0÷135°	0÷105°
LKP00SL	15	ALUMINIUM	LEFT	0,4	0÷135°	0÷105°
UP210151441G	15	STEEL	CENTRAL	0,8	0÷135°	0÷105°
UP210151442G	15	STEEL	RIGHT	0,8	0÷135°	0÷105°
UP210151443G	15	STEEL	LEFT	0,8	0÷135°	0÷105°
UKP5063E	45	ALUMINIUM	CENTRAL	0,45	0÷135°	0÷135°
UKP63F	45	ALUMINIUM	RIGHT	0,45	0÷135°	0÷135°
UKP63L	45	ALUMINIUM	LEFT	0,45	0÷135°	0÷135°
UKP5063ES	45	STEEL	CENTRAL	1,16	0÷135°	0÷135°
UKP63FS	45	STEEL	RIGHT	1,16	0÷135°	0÷135°
UKP63LS	45	STEEL	LEFT	1,16	0÷135°	0÷135°

Sensors



Electronic (optical)

DF-K PNP M12
DF-J NPN M12
DF-Y PNP M12 White LED



Pneumatic

DF-UPNW

Accessories



Self holding system

UBK46P19