

UCBP 40

Pneumatic power clamps Ø40 mm

Pneumatic power clamps with compensation system, toggle-joint mechanism and stepless adjustable opening angle, typically used for handling and holding metal sheets in welding applications

- Lightweight aluminium construction ideal for mounting on grippers
- Compact dimensions
- Integrated compensation system up to 2 mm
- Version with hand lever available
- Fully optical electronic sensor or pneumatic sensor
- Fixing pattern on 4 sides
- Manual unlocking in case of air loss
- Self-holding system for open position available
- Clamping arm in aluminium or steel

CHARACTERISTICS

Operating temperature	5° ÷ 45° C
Min./Max. Operating pressure	0,4 / 0,6 MPa
Opening angle*	0° ÷ 135°
Bore Ø	40 mm
Holding moment	600 Nm
Clamping moment (0,5 MPa)	170 Nm
Weight (clamping arm not included)	1,5 Kg
Pneumatic supply ports	G1/8 on both sides
Sensor	electronic (optical)
Supply voltage	10 ÷ 30 Vdc
IP code	IP65

*The opening angle range may vary according to the arm position and style.

CODIFICATION KEY

UC	B	P	40	O	E	A	K	0	
1	2	3	4	5	6	7	8	9	10

- COMPENSATION
- LIGHTWEIGHT
- IRREVERSIBLE
- ANGLE ADJUSTMENT
- OPTICAL SENSOR
- COMPACT

1 SERIES UC = UNICLAMP Power clamps	6 ARM STYLE C = Central, 15 mm offset D = Right, 15 mm offset S = Left, 15 mm offset E = Central, 45 mm offset F = Right, 45 mm offset L = Left, 45 mm offset N = No arm For other versions contact our Sales Dept.
2 STANDARD B = European standard	7 ARM TYPE A = Aluminium S = Steel N = No arm
3 VERSION P = Pneumatic	8 SENSOR N = No sensor (with protection plate) K = Electronic sensor PNP, M12 (DF-K) D = Pneumatic sensor (DF-UPNW) J = Electronic sensor NPN, optical (DF-J) Y = Electronic sensor PNP, M12 (DF-Y) white LED
4 SIZE 40 = Ø 40 mm	9 PRODUCT REVISION Assigned by UNIVER
5 ARM POSITION V = 90°	10 ATEX X = ATEX option See ATEX Catalogue for types and versions
O = 180°	
N = No arm	

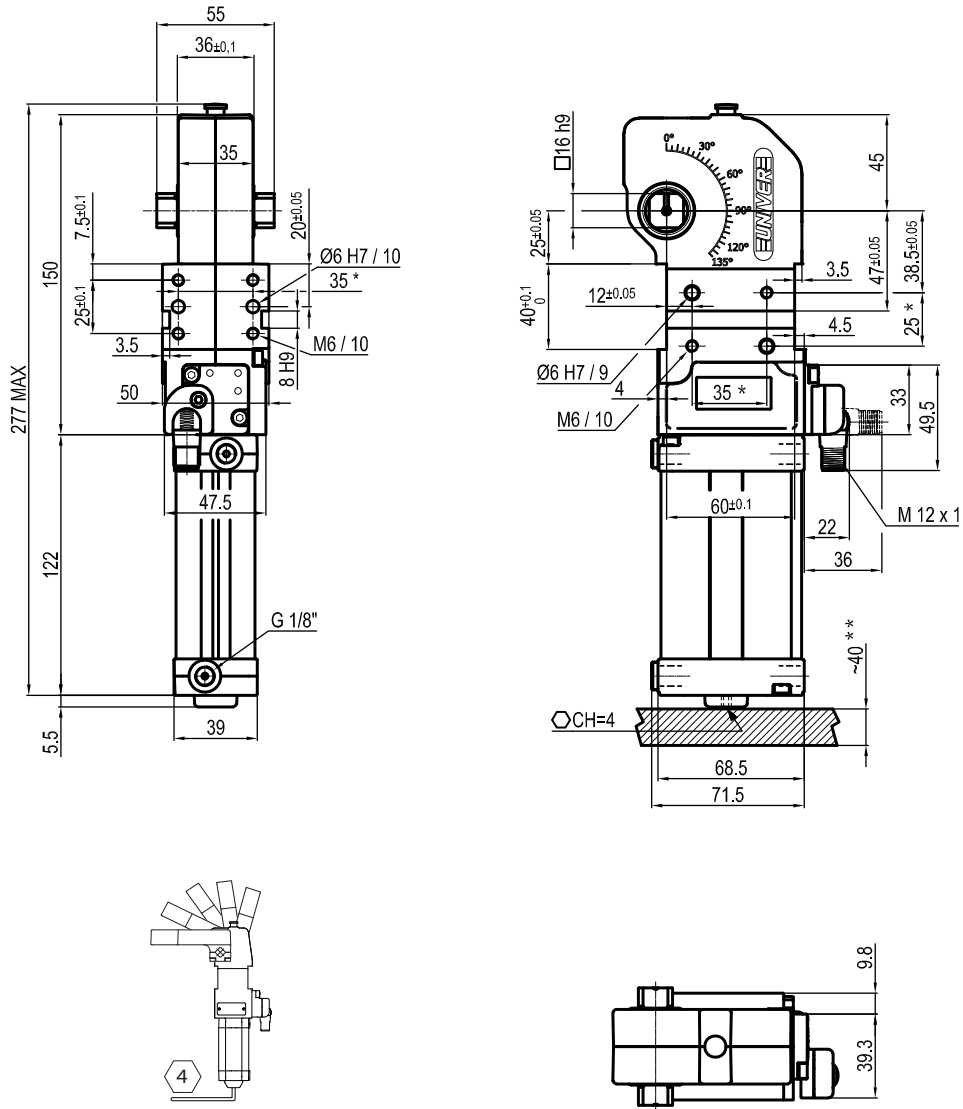

*TOLERANCE BETWEEN DOWELS ± 0,02 BETWEEN SCREW HOLES ± 0,1
 **AREA TO ACCESS ANGLE ADJUSTMENT

Maximum Applicable Load

Pressure: 5 bar - 90° cycle time (Open - Close)

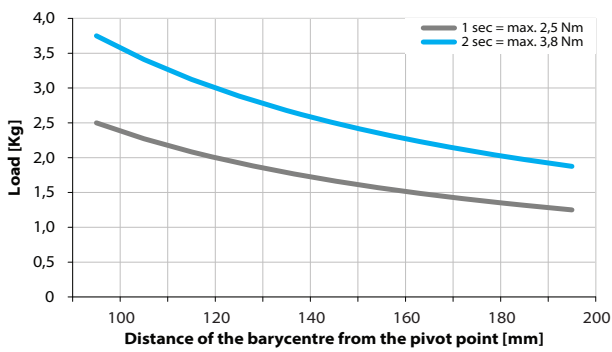

Air Consumption per Cycle

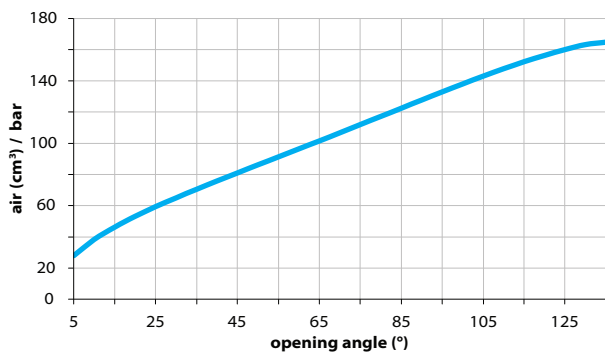

Clamping Arms

Arm Offset 15mm

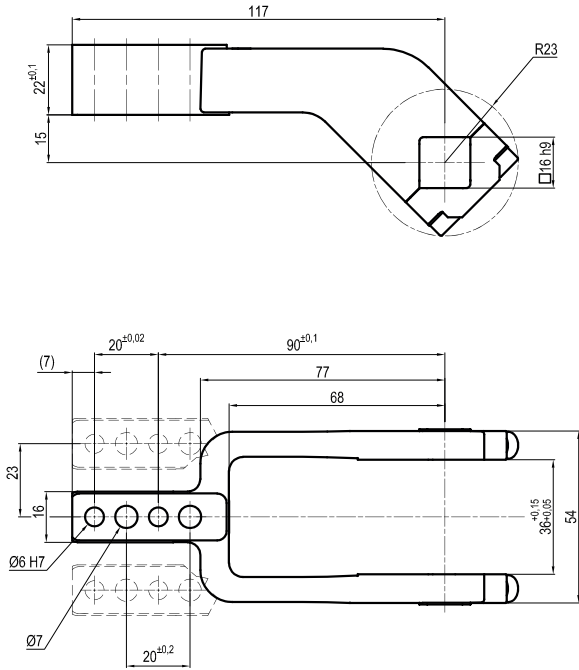

Arm Offset 45mm

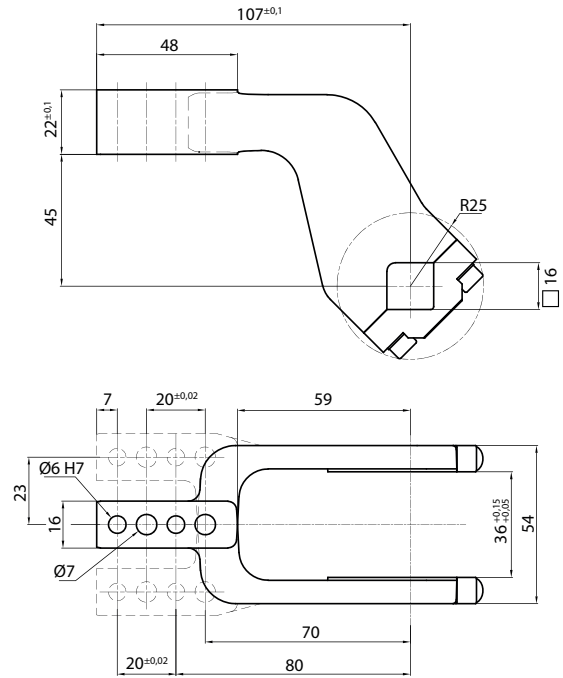

Armcode	Offset	Material	Arm style	Weight (Kg)	Opening angle (90°)	Opening angle (180°)
LKP01CST	15	ALUMINIUM	CENTRAL	0,2	0±135°	0±125°
LKP01DST	15	ALUMINIUM	RIGHT	0,2	0±135°	0±125°
LKP01SST	15	ALUMINIUM	LEFT	0,2	0±135°	0±125°
UP120151441S	15	STEEL	CENTRAL	0,4	0±135°	0±125°
UP120151442S	15	STEEL	RIGHT	0,4	0±135°	0±125°
UP120151443S	15	STEEL	LEFT	0,4	0±135°	0±125°
UKP01E	45	ALUMINIUM	CENTRAL	0,25	0±125°	0±135°
UKP01F	45	ALUMINIUM	RIGHT	0,25	0±125°	0±135°
UKP01L	45	ALUMINIUM	LEFT	0,25	0±125°	0±135°
UKP01ES	45	STEEL	CENTRAL	0,4	0±125°	0±135°
UKP01FS	45	STEEL	RIGHT	0,4	0±125°	0±135°
UKP01LS	45	STEEL	LEFT	0,4	0±125°	0±135°

Sensors



Electronic (optical)

DF-K PNP M12
DF-J NPN M12
DF-Y PNP M12 White LED



Pneumatic

DF-UPNW

Accessories



Self holding system

UBK46P16 For arm 15 offset
UBK46P16-45 For arm 45 offset