

UP310151441A

□ 22 mm - offset 15 mm

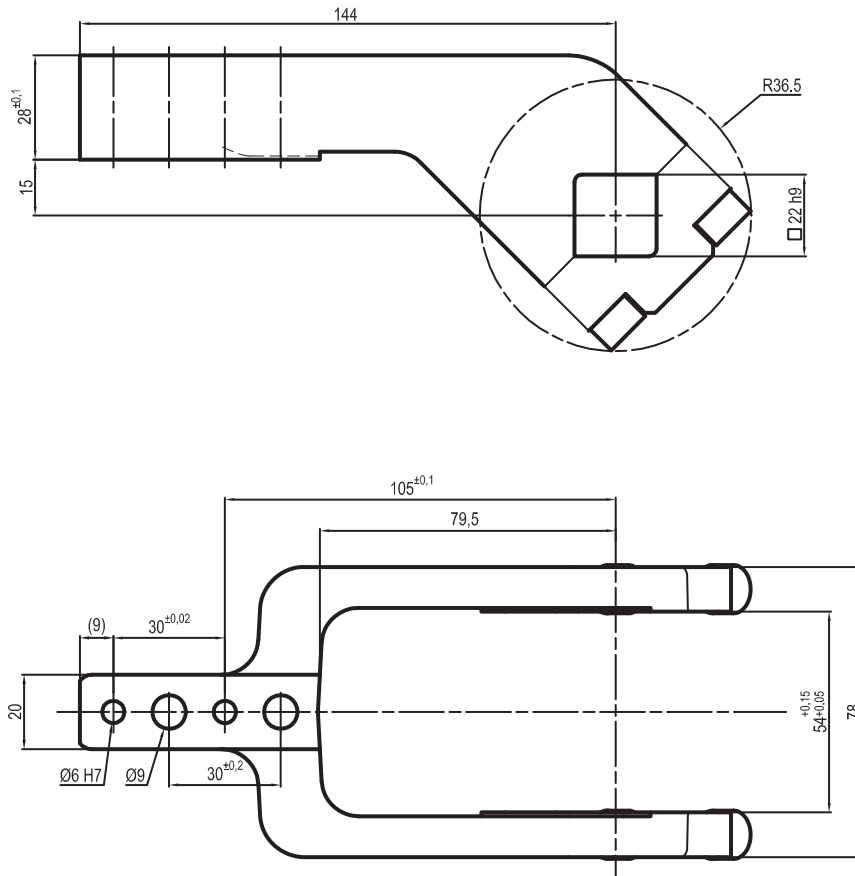

Clamp size	Material	Weight
63 mm	Aluminium	0,3 Kg

THE CLAMPING ARM INCLUDES THE NECESSARY SCREWS

Subject to technical modifications without notice

Rev. 02 28.04.16

UP310151442A

□ 22 mm - offset 15 mm

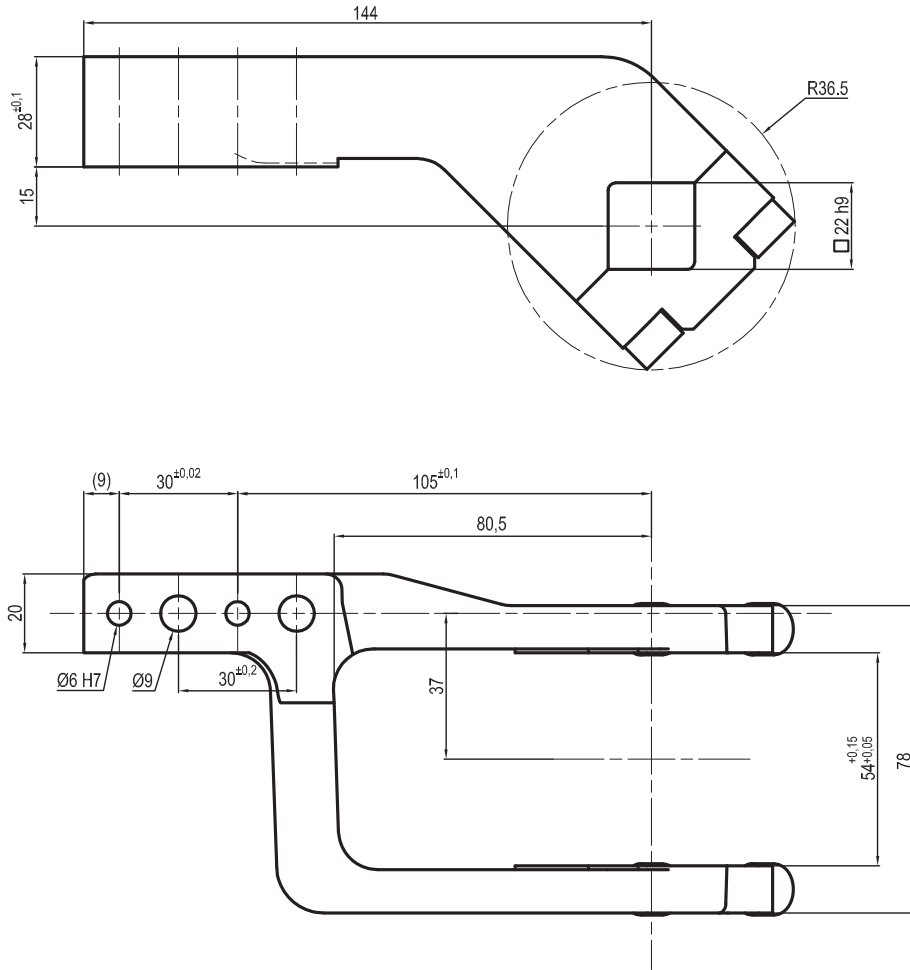

Clamp size	Material	Weight
63 mm	Aluminium	0,3 Kg

THE CLAMPING ARM INCLUDES THE NECESSARY SCREWS

Subject to technical modifications without notice

Rev. 03 15.07.16

UP310151443A

□ 22 mm - offset 15 mm

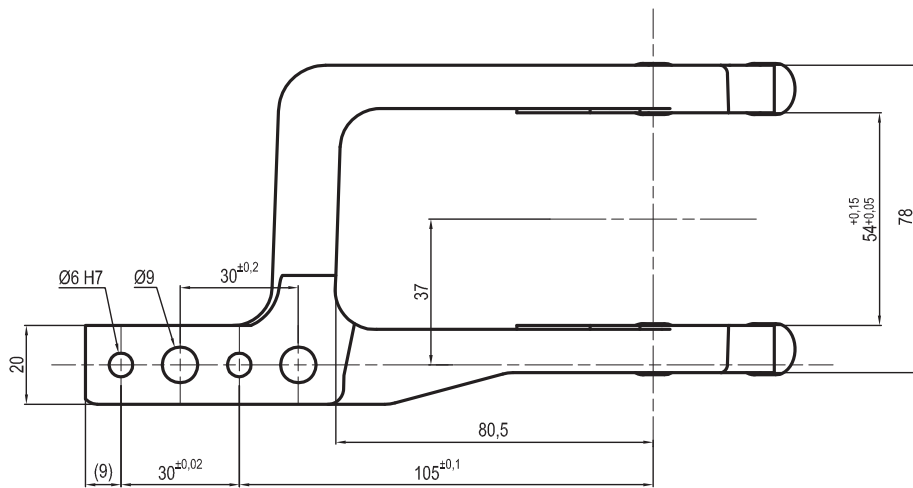
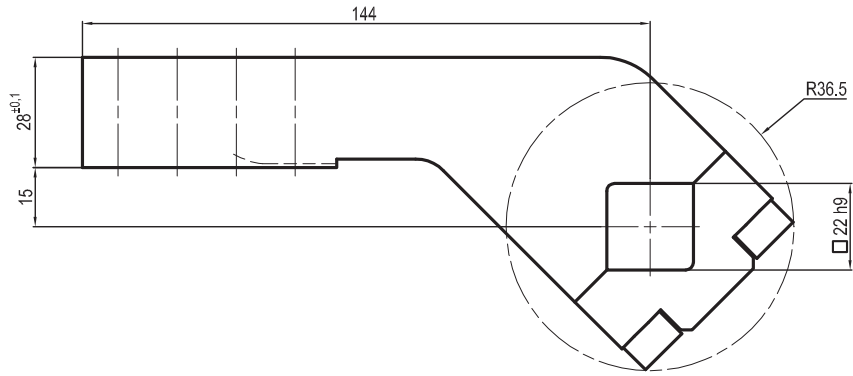

Clamp size	Material	Weight
63 mm	Aluminium	0,3 Kg

THE CLAMPING ARM INCLUDES THE NECESSARY SCREWS

Subject to technical modifications without notice

Rev. 03 15.07.16

UP310151441S

□ 22 mm - offset 15 mm

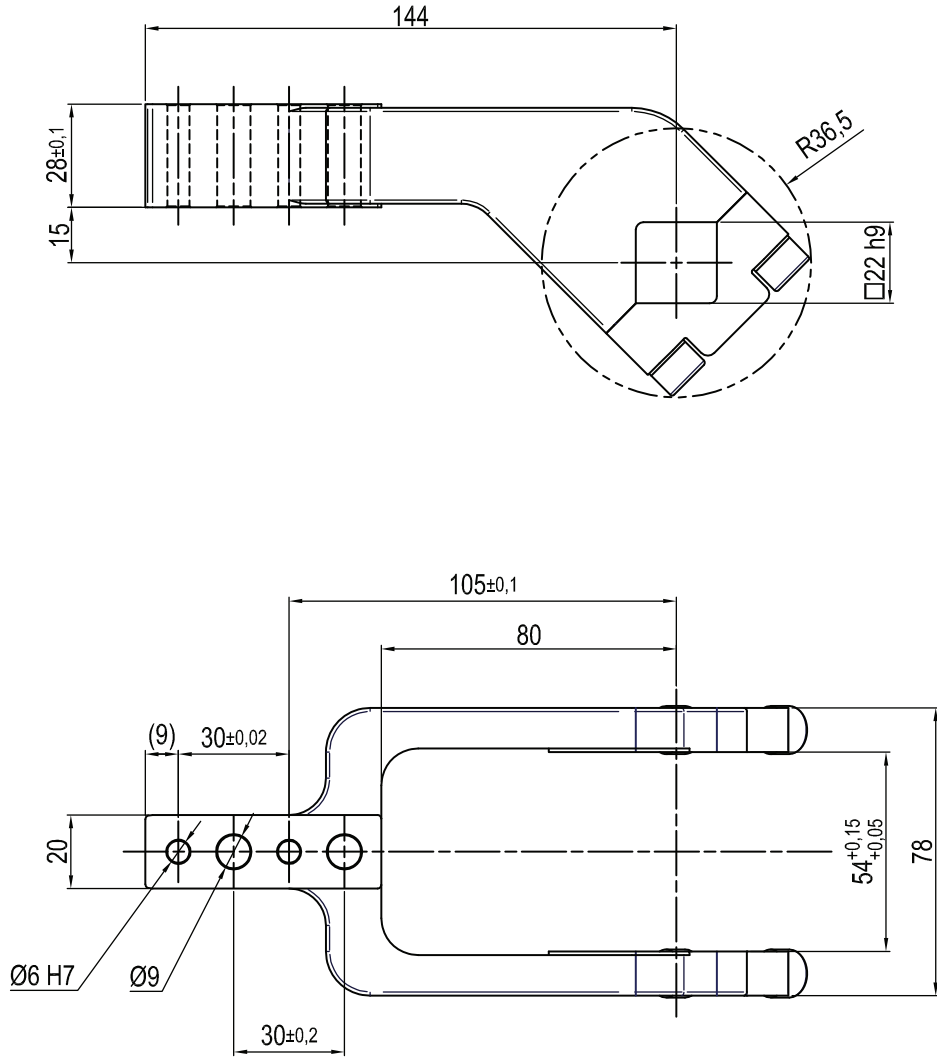

Clamp size	Material	Weight
63 mm	Steel	1,2 Kg

THE CLAMPING ARM INCLUDES THE NECESSARY SCREWS

Subject to technical modifications without notice

Rev. 00 26.08.20

UP310151442S

□ 22 mm - offset 15 mm

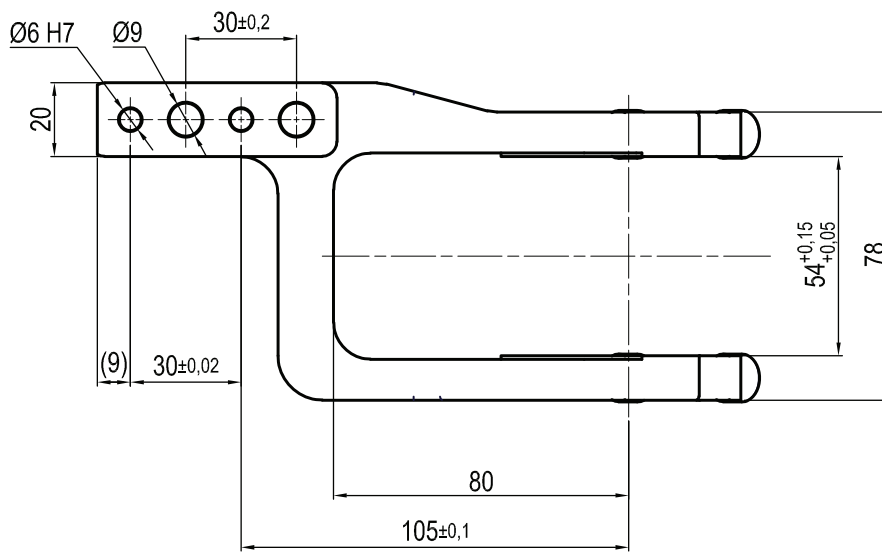
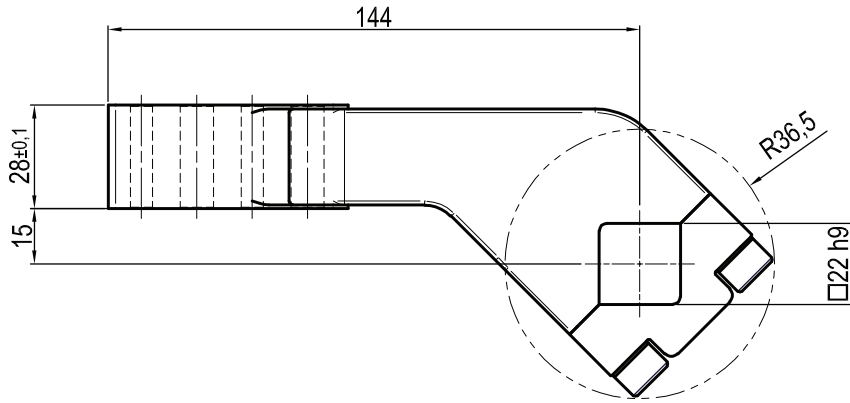

Clamp size	Material	Weight
63 mm	Steel	1,2 Kg

THE CLAMPING ARM INCLUDES THE NECESSARY SCREWS

Subject to technical modifications without notice

Rev. 00 26.08.20

UP310151443S

□ 22 mm - offset 15 mm

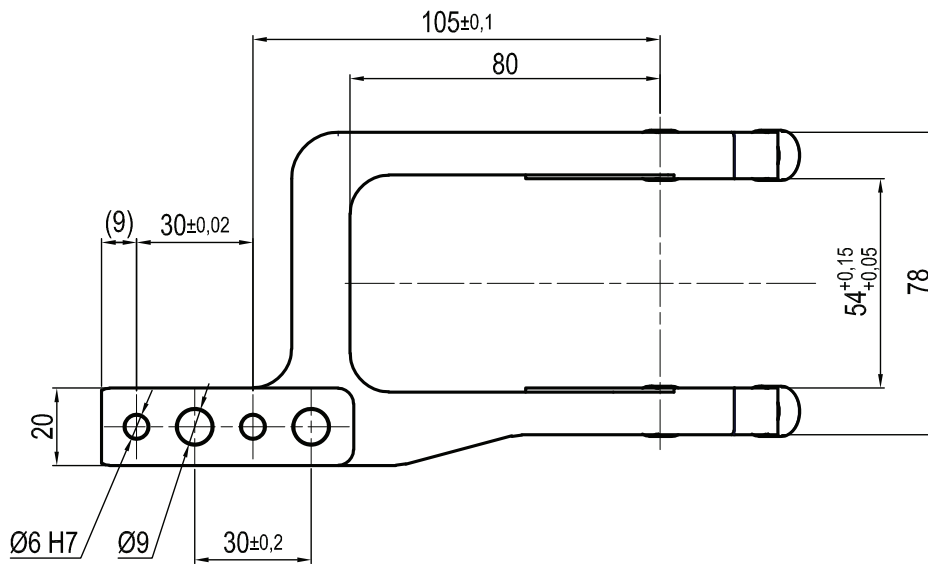
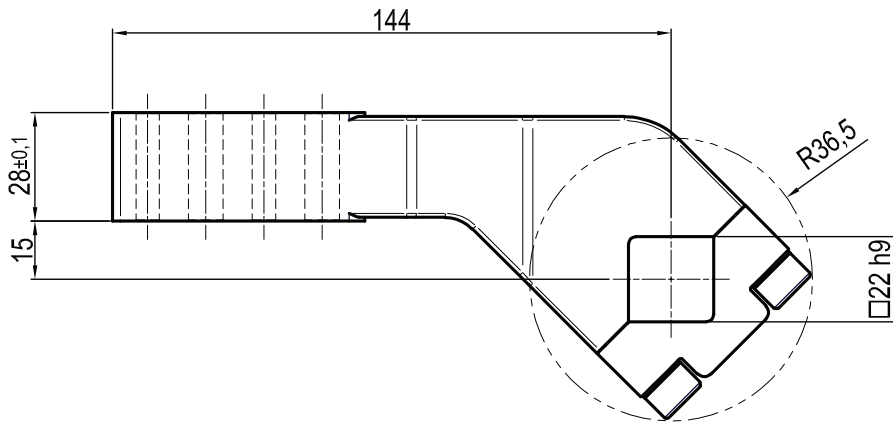

Clamp size	Material	Weight
63 mm	Steel	1,2 Kg

THE CLAMPING ARM INCLUDES THE NECESSARY SCREWS

Subject to technical modifications without notice

Rev. 00 25.08.20

LKP010-2311/2312

□ 22 mm - offset 15 mm

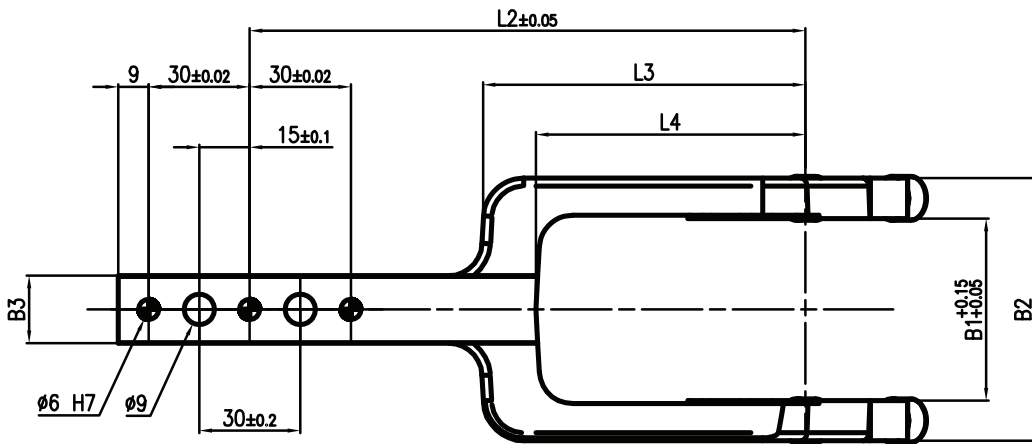
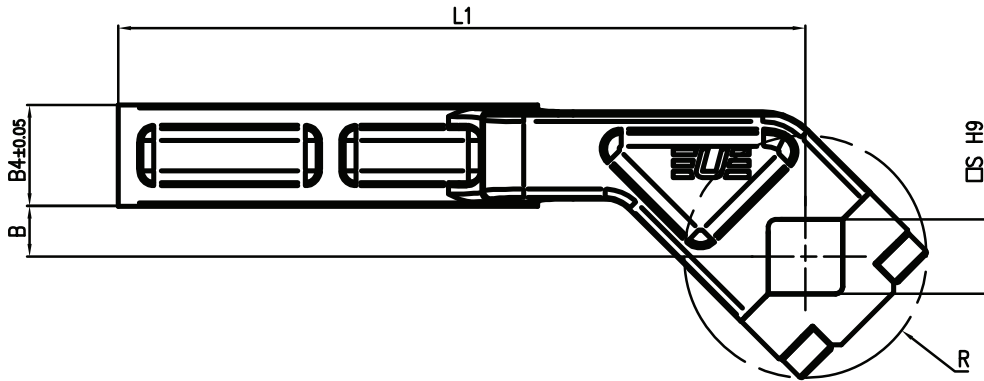

Part no.	B	B1	B2	B3	B4	L1	L2	L3	L4	R	S	Material
LKP010-2311	15	54	78	20	30	144	105	95	80	36	22	Steel
LKP010-2312	15	54	78	20	30	204	165	95	80	36	22	Steel