

UCNM80

Unità di bloccaggio UNICLAMP con leva manuale standard NAAMS

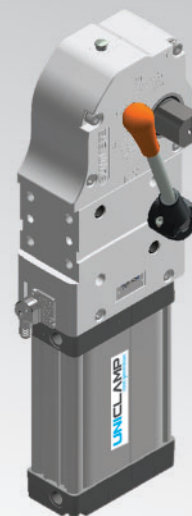

U	C	N	M	8	0	N	N	K	G	0
1	2	3		4		5	6	7	8	9



1 Serie	2 Standard	3 Versione
----------------	-------------------	-------------------

UC = Unità di bloccaggio UNICLAMP con regolazione continua angolo d'apertura da: 0° a 135° max

N = NAAMS Standard

M = Pneumatica con leva manuale

4 Taglia	5 Posizione pressore	6 Uscita albero quadro
-----------------	-----------------------------	-------------------------------

80 = Ø 80 mm

N = Senza pressore

R = Solo lato destro
L = Solo lato sinistro
N = Entrambi i lati

7 Sensore	8 Filetto alimentazioni	9 Revisione prodotto
------------------	--------------------------------	-----------------------------

N = Senza sensore (con piastra di chiusura)
K = Sensore elettronico PNP (ottico) (DF-K)

G = Gas
N = NPT

Assegnato da UNIVER

UCNM80NNKG0

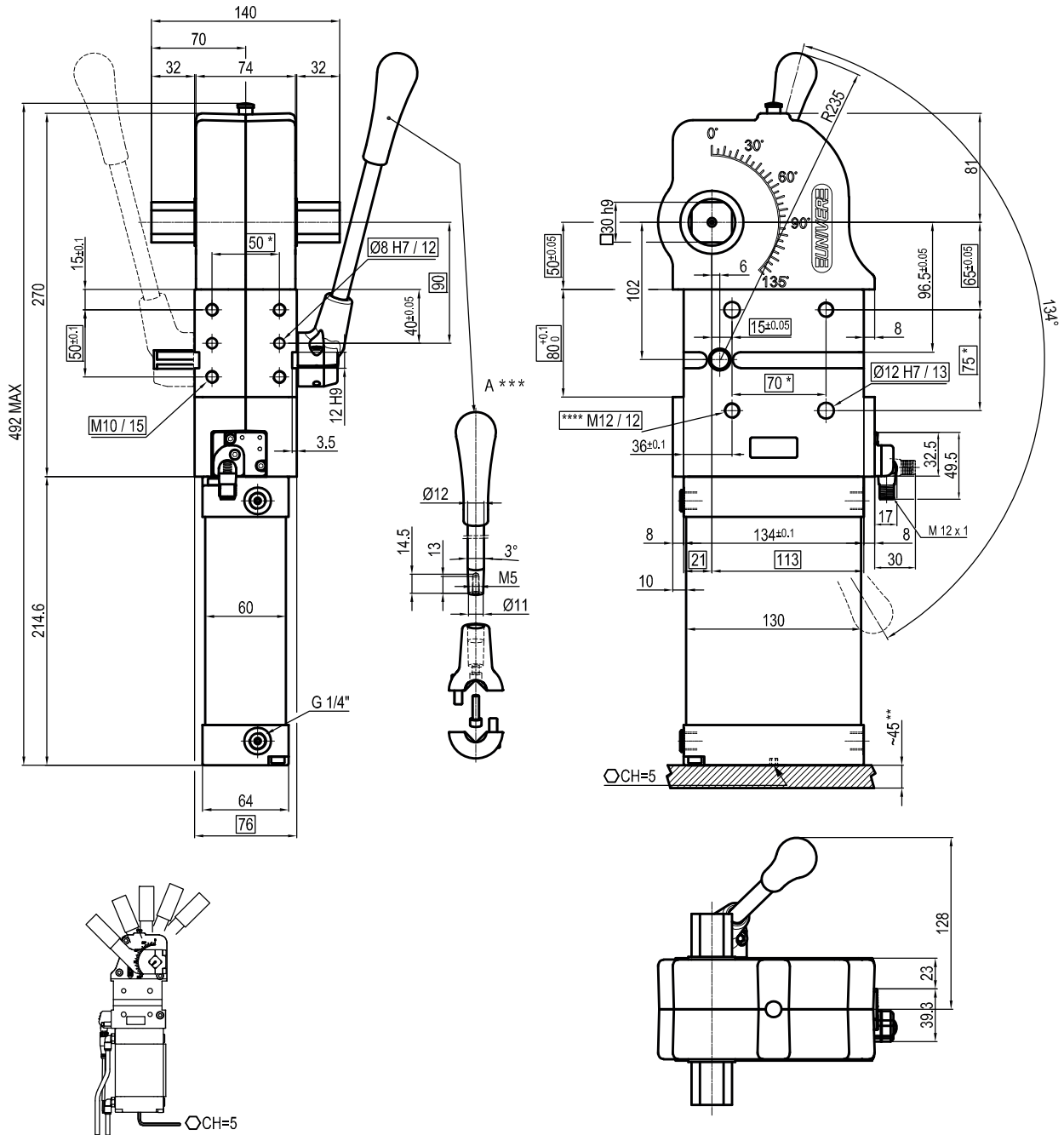

Bore Ø	Holding moment	Clamping moment (0,5 MPa)	Weight (clamping arm not included)
Ø80 mm	4000 Nm	1100 Nm	9,5 Kg

Min./Max. operating pressure: **0,4 / 0,6 MPa**

Operating temperature: **5° ÷ 45° C**

Opening angle: **adjustable**

Without arm
With manual lever

Electronic sensor with M12 swivel connector, from 0° to 90°,

in steps of 10°

Supply voltage: 10 ÷ 30 Vdc

IP code: **IP 65**

Pneumatic ports on both sides

* : TOLERANCE BETWEEN DOWELS ± 0,02, BETWEEN SCREW HOLES ± 0,1

** : AREA TO ACCESS ANGLE ADJUSTMENT

***: DIMENSIONS TO BE RESPECTED IN CASE OTHER MANUAL LEVERS ARE USED

****: SCREW THREAD INSERT

Subject to technical modifications without notice

UCNM80NNKN0

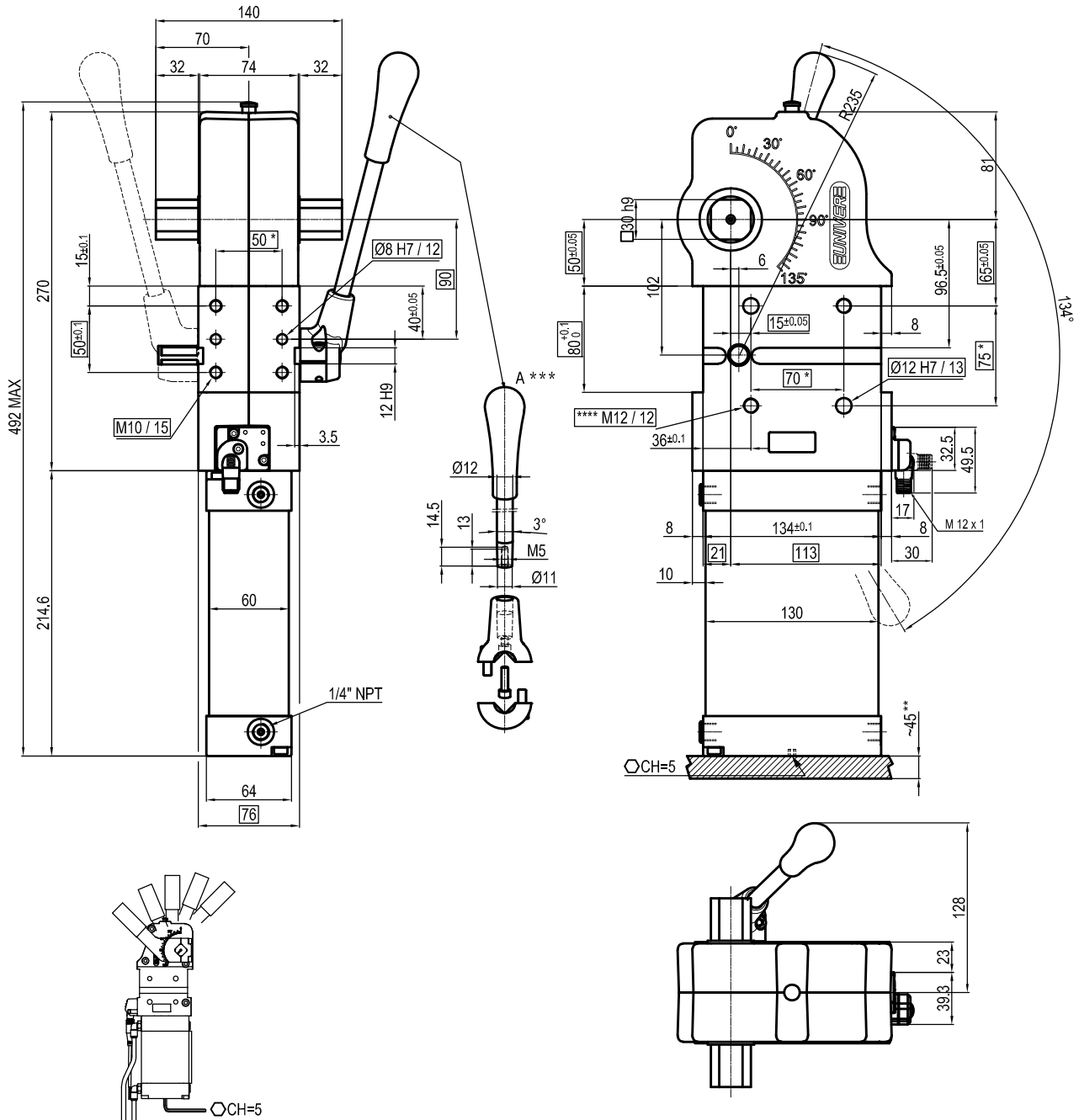

Bore Ø	Holding moment	Clamping moment (0,5 MPa)	Weight (clamping arm not included)
Ø80 mm	4000 Nm	1100 Nm	9,5 Kg

Min./Max. operating pressure: **0,4 / 0,6 MPa**

Operating temperature: **5° ÷ 45° C**

Opening angle: **adjustable**

Without arm

With manual lever

Electronic sensor with M12 swivel connector, from 0° to 90°

in steps of 10°

Supply voltage: 10 ÷ 30 Vdc

IP code: **IP 65**

Pneumatic ports on both sides

* : TOLERANCE BETWEEN DOWELS ± 0,02, BETWEEN SCREW HOLES ± 0,1

** : AREA TO ACCESS ANGLE ADJUSTMENT

***: DIMENSIONS TO BE RESPECTED IN CASE OTHER MANUAL LEVERS ARE USED

****: SCREW THREAD INSERT

Subject to technical modifications without notice

UCNM80NLKG0

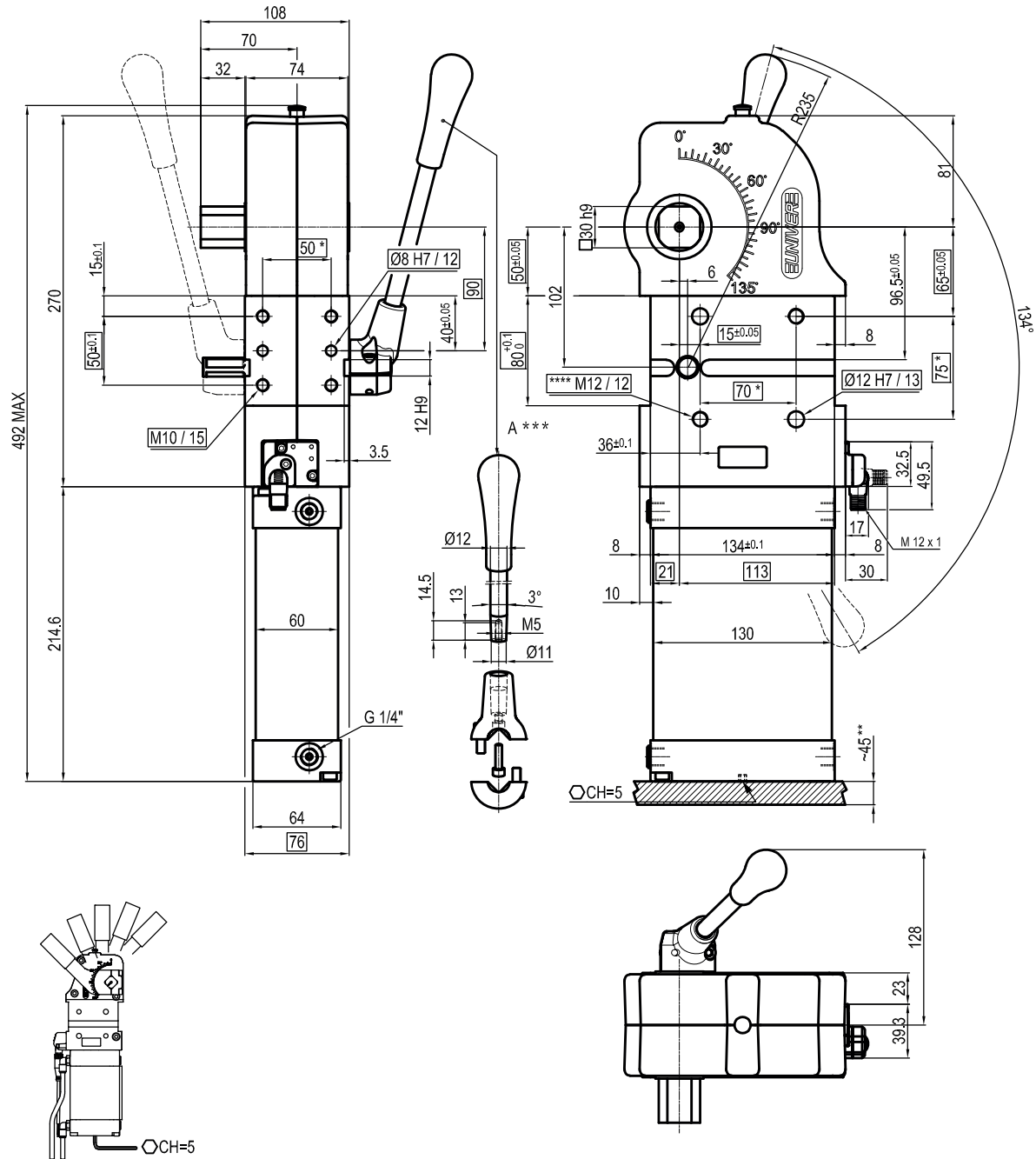

Bore Ø	Holding moment	Clamping moment (0,5 MPa)	Weight (clamping arm not included)
Ø80 mm	4000 Nm	1100 Nm	9,5 Kg

Min./Max. operating pressure: **0,4 / 0,6 MPa**
 Operating temperature: **5° ÷ 45° C**
 Opening angle: **adjustable**
 Without arm
 With manual lever
 Electronic sensor with M12 swivel connector, from 0° to 90°, in steps of 10°
 Supply voltage: 10 ÷ 30 Vdc
 IP code: **IP 65**
 Pneumatic ports on both sides

* : TOLERANCE BETWEEN DOWELS ± 0,02, BETWEEN SCREW HOLES ± 0,1
 ** : AREA TO ACCESS ANGLE ADJUSTMENT
 *** : DIMENSIONS TO BE RESPECTED IN CASE OTHER MANUAL LEVERS ARE USED
 **** : SCREW THREAD INSERT

Subject to technical modifications without notice

UCNM80NLKN0

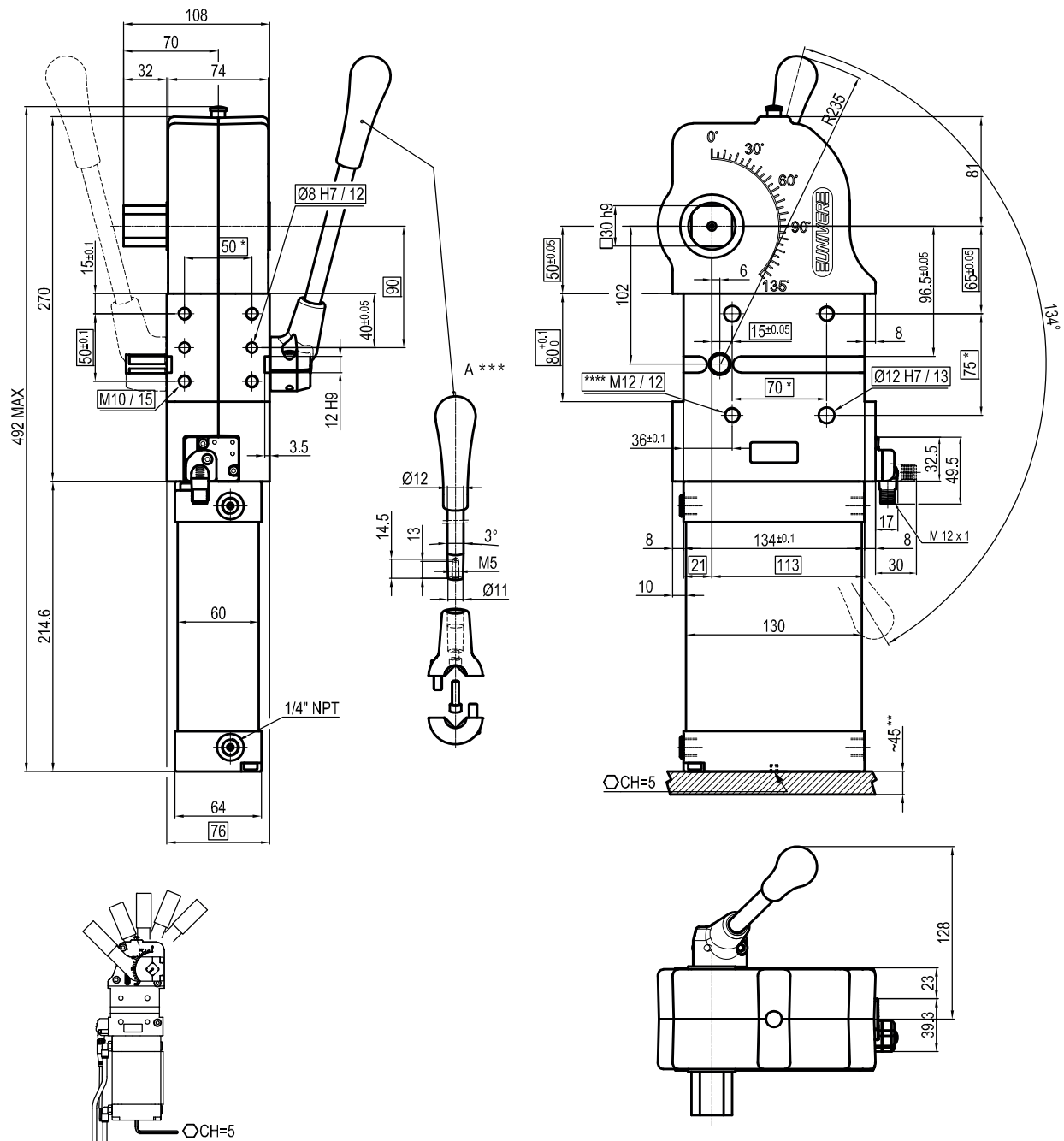

Bore Ø	Holding moment	Clamping moment (0,5 MPa)	Weight (clamping arm not included)
Ø80 mm	4000 Nm	1100 Nm	9,5 Kg

* : TOLERANCE BETWEEN DOWELS $\pm 0,02$, BETWEEN SCREW HOLES $\pm 0,1$
 ** : AREA TO ACCESS ANGLE ADJUSTMENT
 *** : DIMENSIONS TO BE RESPECTED IN CASE OTHER MANUAL LEVERS ARE USED
 **** : SCREW THREAD INSERT

Subject to technical modifications without notice

Rev. 02 26.01.22

Min./Max. operating pressure: **0,4 / 0,6 MPa**
 Operating temperature: **5° ÷ 45° C**
 Opening angle: **adjustable**
 Without arm
 With manual lever
 Electronic sensor with M12 swivel connector, from 0° to 90°, in steps of 10°
 Supply voltage: 10 ÷ 30 Vdc
 IP code: **IP 65**
 Pneumatic ports on both sides

UCNM80NRKG0

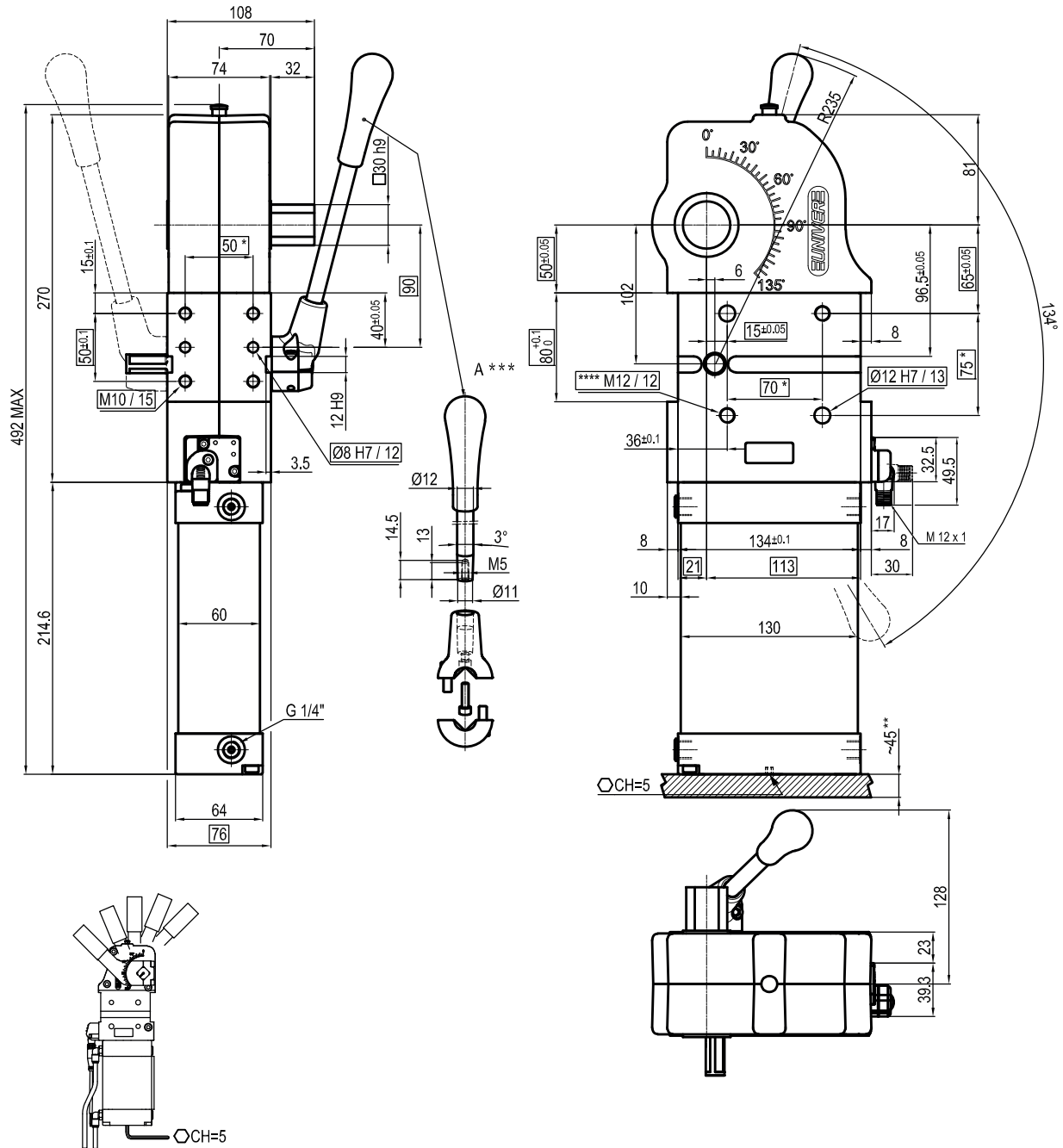

Bore Ø	Holding moment	Clamping moment (0,5 MPa)	Weight (clamping arm not included)
Ø80 mm	4000 Nm	1100 Nm	9,5 Kg

* : TOLERANCE BETWEEN DOWELS ± 0,02, BETWEEN SCREW HOLES ± 0,1
 ** : AREA TO ACCESS ANGLE ADJUSTMENT
 *** : DIMENSIONS TO BE RESPECTED IN CASE OTHER MANUAL LEVERS ARE USED
 **** : SCREW THREAD INSERT

Subject to technical modifications without notice

Min./Max. operating pressure: **0,4 / 0,6 MPa**
 Operating temperature: **5° ÷ 45° C**
 Opening angle: **adjustable**
 Without arm
 With manual lever
 Electronic sensor with M12 swivel connector, from 0° to 90°, in steps of 10°
 Supply voltage: 10 ÷ 30 Vdc
 IP code: **IP 65**
 Pneumatic ports on both sides

