

# UCBP63

UNICLAMP Power clamp

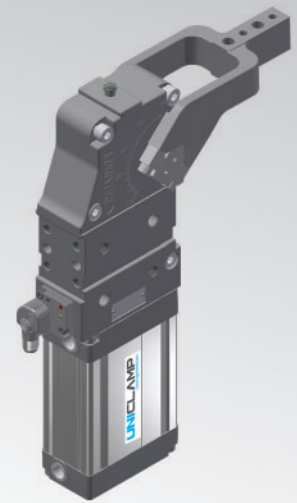

U	C	B	P	6	3	O	E	A	K	O
1	2	3	4	5	6	7	8	9	8	9

1 Series	2 Standard	3 Modell	4 Size
----------	------------	----------	--------

**UC = UNICLAMP Power clamp**  
 fully adjustable opening angle:  
**0° to 135° Max**  
 The opening angle range may vary  
 according to the arm position and style

**B = European standard**

**P = Pneumatic** □ 19

**63 = Ø 63 mm**

5 Arm position	6 Arm style
----------------	-------------

**V = 90°**     **O = 180°**     **N = No arm**

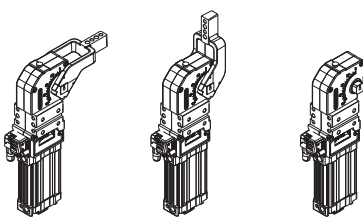

**C = Central, 15 mm Offset**     \* = Available upon request  
**D = Right, 15 mm Offset**  
**S = Left, 15 mm Offset**  
**E = Central, 45 mm Offset**  
**F = Right, 45 mm Offset**  
**L = Left, 45 mm Offset**  
**X\* = Central, oversized dowel holes Ø 8 H7, 15 mm Offset**  
**Y\* = Right, oversized dowel holes Ø 8 H7, 15 mm Offset**  
**Z\* = Left, oversized dowel holes Ø 8 H7, 15 mm Offset**  
**T\* = Central, oversized dowel holes Ø 8 H7, 45 mm Offset**  
**U\* = Right, oversized dowel holes Ø 8 H7, 45 mm Offset**  
**V\* = Left, oversized dowel holes Ø 8 H7, 45 mm Offset**  
**N = No arm**

7 Arm type	8 Sensor	9 Product revision
------------	----------	--------------------

**A = Aluminum**  
**S = Steel**  
**N = No arm**

**N = No sensor (with protection plate)**  
**K = Electronic sensor PNP (optical) (DF-K)**  
**D = Pneumatic sensor**  
**J = Electronic sensor NPN (optical) (DF-J)**  
**Y = Electronic sensor PNP (optical) (DF-Y) white led**

Assigned by UNIVER

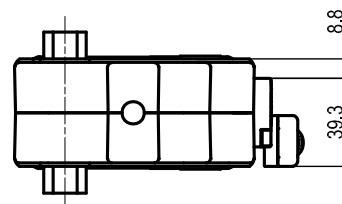
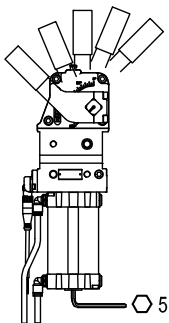
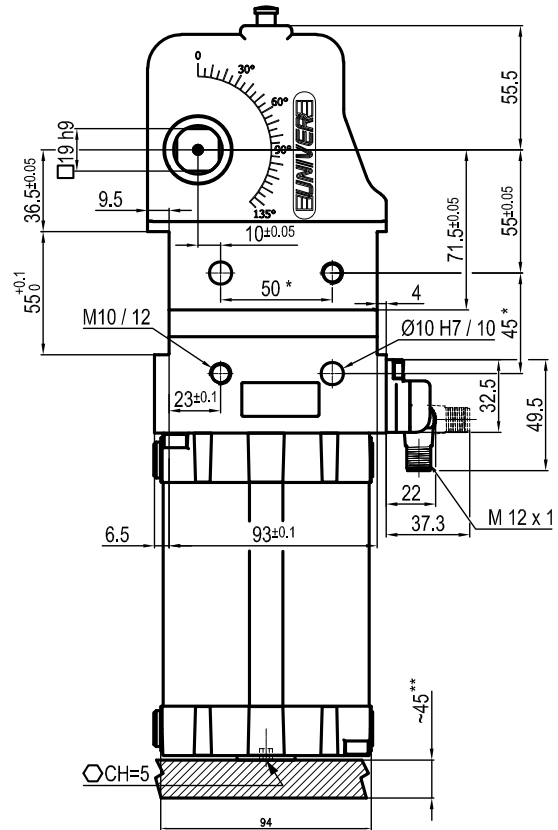
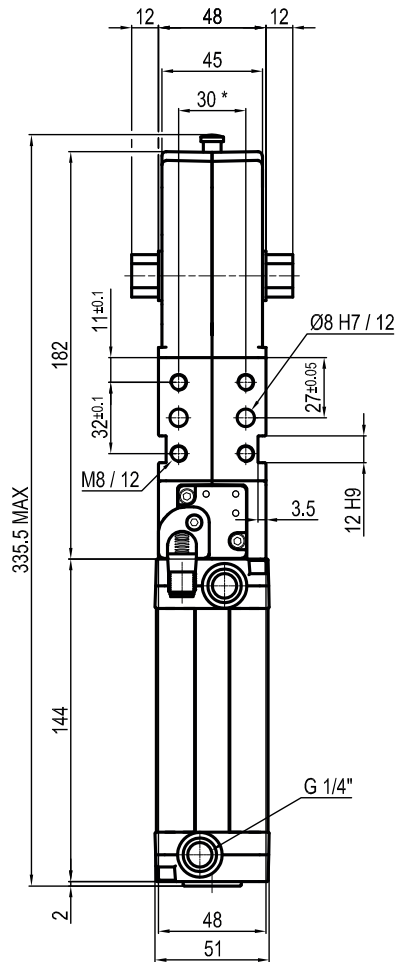
**UCBP63NNNK0**

Bore Ø	Holding moment	Clamping moment (0,5 MPa)	Weight (clamping arm not included)
63 mm	1750 Nm	420 Nm	2,9 Kg

 Min./Max. operating pressure: **0,4 / 0,6 MPa**

 Operating temperature: **5° ÷ 45° C**

 Opening angle: **adjustable**

Without arm

Electronic sensor with M12 swivel connector, from 0° to 90°, in steps of 10°

Supply voltage: 10 ÷ 30 Vdc

 IP code: **IP 65**

Pneumatic ports on both sides

\*: TOLERANCE BETWEEN DOWELS ± 0,02, BETWEEN SCREW HOLES ± 0,1

\*\*: AREA TO ACCESS ANGLE ADJUSTMENT

Subject to technical modifications without notice

Rev. 02 26.01.22

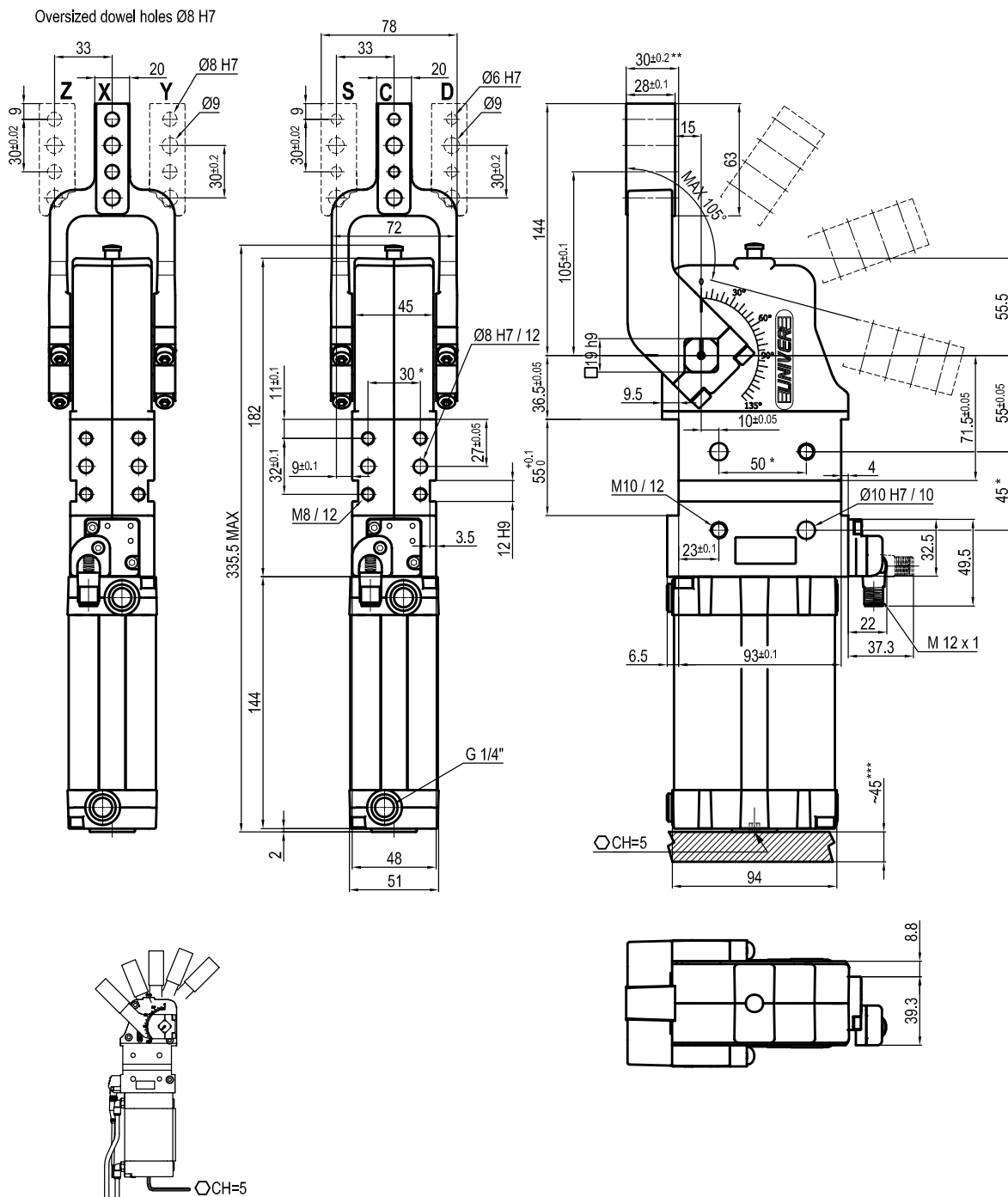

Bore Ø	Holding moment	Clamping moment (0,5 MPa)	Weight (clamping arm not included)
63 mm	1750 Nm	420 Nm	2,9 Kg

\* : TOLERANCE BETWEEN DOWELS  $\pm 0,02$ , BETWEEN SCREW HOLES  $\pm 0,1$   
 \*\* : TOLERANCE AT 80 mm FROM PIVOT POINT  
 \*\*\* : AREA TO ACCESS ANGLE ADJUSTMENT

Min./Max. operating pressure: **0,4 / 0,6 MPa**  
 Operating temperature: **5° ÷ 45° C**  
 Opening angle: **adjustable from 0° to 105°**  
 Arm position: **180°**  
 Electronic sensor with M12 swivel connector, from 0° to 90°, in steps of 10°  
 Supply voltage: 10 ÷ 30 Vdc  
 IP code: **IP 65**  
 Pneumatic ports on both sides

## UCBP63O\_\_K0

45 mm

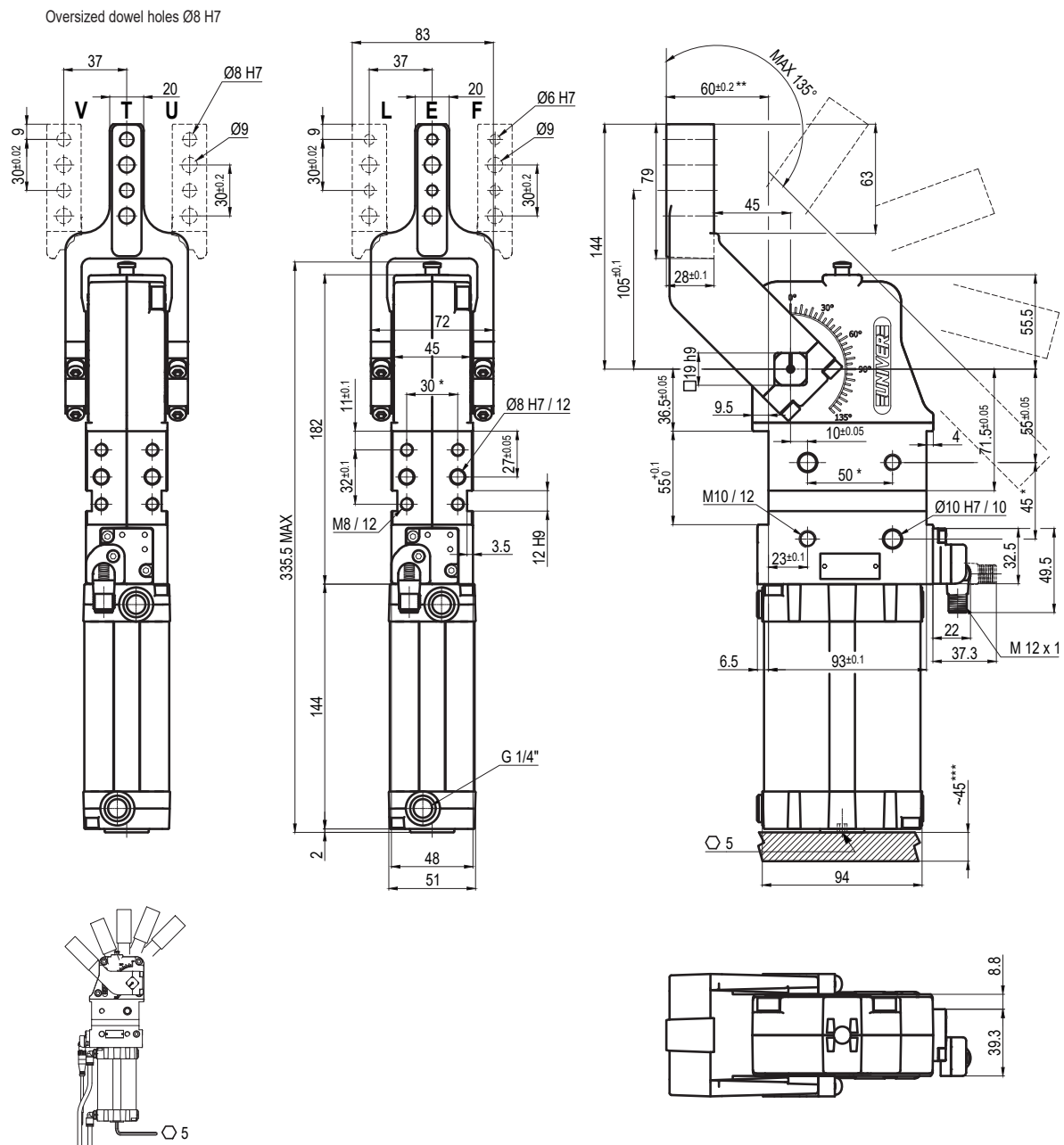

Bore Ø	Holding moment	Clamping moment (0,5 MPa)	Weight (clamping arm not included)
63 mm	1750 Nm	420 Nm	2,9 Kg

\* : TOLERANCE BETWEEN DOWELS  $\pm 0,02$ , BETWEEN SCREW HOLES  $\pm 0,1$

\*\* : TOLERANCE AT 80 mm FROM PIVOT POINT

\*\*\* : AREA TO ACCESS ANGLE ADJUSTMENT

Min./Max. operating pressure: **0,4 / 0,6 MPa**

Operating temperature: **5° ÷ 45° C**

Opening angle: **adjustable from 0° to 135°**

Arm position: **180°**

Electronic sensor with M12 swivel connector, from 0° to 90°, in steps of 10°

Supply voltage: 10 ÷ 30 Vdc

IP code: **IP 65**

Pneumatic ports on both sides

Subject to technical modifications without notice

Rev. 00 31.10.19

UCBP63V\_\_K0

15 mm

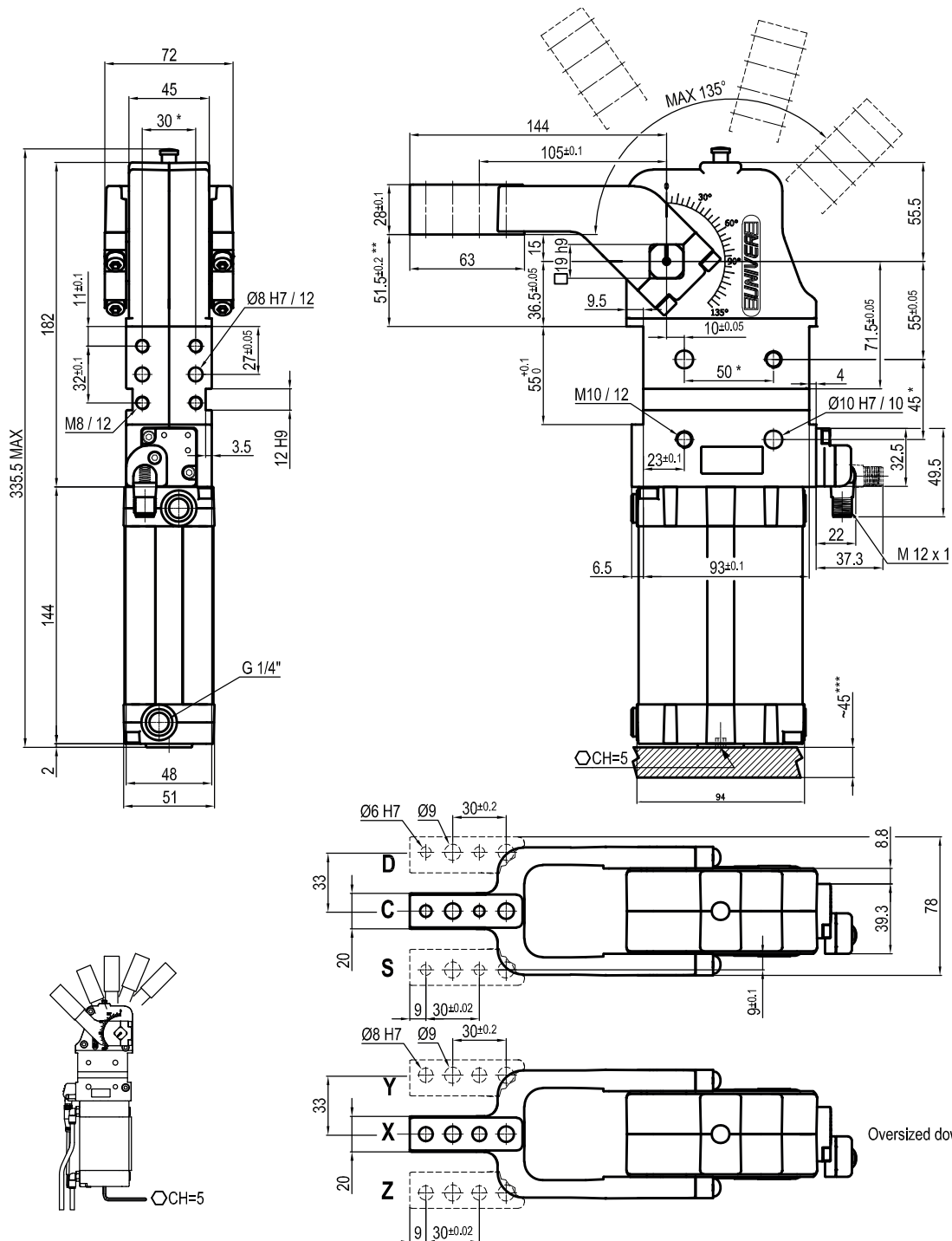

Bore Ø	Holding moment	Clamping moment (0,5 MPa)	Weight (clamping arm not included)
63 mm	1750 Nm	420 Nm	2,9 Kg

Min./Max. operating pressure: **0,4 / 0,6 MPa**  
 Operating temperature: **5° ÷ 45° C**  
 Opening angle: **adjustable from 0° to 135°**  
 Arm position: **90°**  
 Electronic sensor with M12 swivel connector, from 0° to 90°, in steps of 10°  
 Supply voltage: 10 ÷ 30 Vdc  
 IP code: **IP 65**  
 Pneumatic ports on both sides

\* : TOLERANCE BETWEEN DOWELS ± 0,02, BETWEEN SCREW HOLES ± 0,1  
 \*\* : TOLERANCE AT 80 mm FROM PIVOT POINT  
 \*\*\* : AREA TO ACCESS ANGLE ADJUSTMENT

## UCBP63V\_\_K0

45 mm

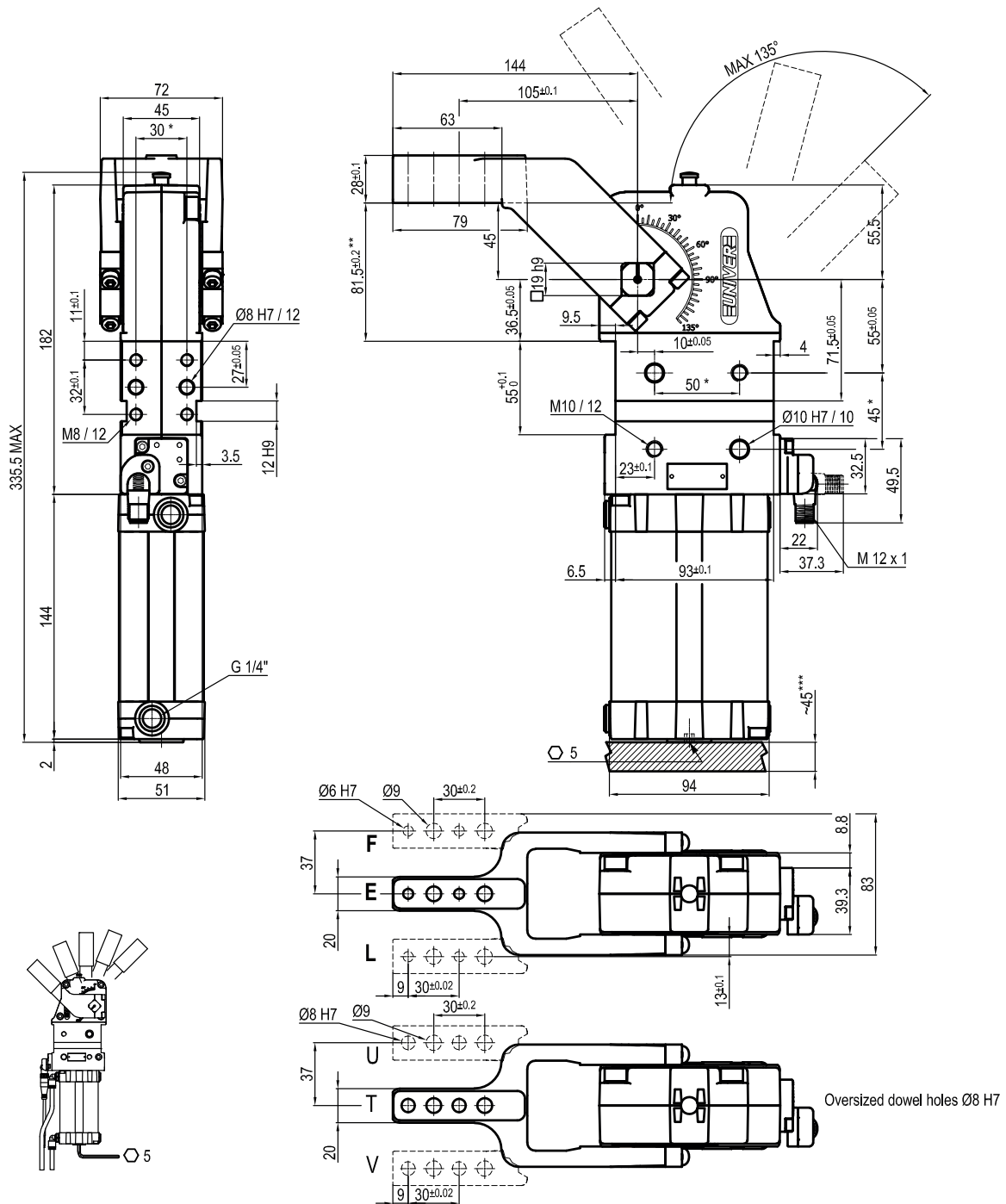

Bore Ø	Holding moment	Clamping moment (0,5 MPa)	Weight (clamping arm not included)
63 mm	1750 Nm	420 Nm	2,9 Kg

 Min./Max. operating pressure: **0,4 / 0,6 MPa**

 Operating temperature: **5° ÷ 45° C**

 Opening angle: **adjustable from 0° to 135°**

 Arm position: **90°**

Electronic sensor with M12 swivel connector, from 0° to 90°, in steps of 10°

Supply voltage: 10 ÷ 30 Vdc

 IP code: **IP 65**

Pneumatic ports on both sides

\*: TOLERANZ ZWISCHEN STIFTBOHRUNGEN ± 0,02 , GEWINDEBOHRUNGEN ± 0,1

\*\*: TOLERANZ BEI 80 mm VOM DREHPUNKT

\*\*\*: ZUGANG ZUR WINKLEINSTELLUNG

Technische Änderungen vorbehalten

Rev. 00 31.10.19