

# UAGP

Unità rotante pneumatica UNICLAMP



U	A	G	P	0	8	0	O	A	0	9	0	B	S	0
1	2	3	4	5	6	7	8	9						

1 Serie	2 Versione	3 Taglia
---------	------------	----------

**UAG** = Unità rotante con angoli di rotazione determinati UNICLAMP

**P** = Pneumatica

<b>075</b> = 75Nm Ø80 mm	<b>215</b> = 210Nm Ø125 mm
<b>080</b> = 60Nm Ø80 mm	<b>300</b> = 300Nm Ø160 mm
<b>120</b> = 110Nm Ø100 mm	<b>350</b> = 350Nm Ø160 mm
<b>150</b> = 120Nm Ø100 mm	<b>355</b> = 350Nm Ø160 mm
<b>155</b> = 120Nm Ø100 mm	<b>600</b> = 600Nm Ø200 mm
<b>170</b> = 170Nm Ø125 mm	<b>605</b> = 600Nm Ø200 mm
<b>210</b> = 210Nm Ø125 mm	

4 Posizione tavola	5 Sensore	6 Angoli di rotazione
--------------------	-----------	-----------------------

**V** = Verticale 180°  
**O** = Orizzontale 90°  
**Z** = Verticale, speculare alla posizione V  
**P** = Orizzontale, speculare alla posizione O (massima apertura angolare 60°)

**K** = Sensore elettronico PNP (ottico) (DF-K)  
**A** = Sensore elettronico PNP (ottico) per angolo di apertura (DF-K) + sensore freno DF-U)

**120** = 120°  
**090** = 90°  
**060** = 60°  
**045** = 45°

7 Blocco di stazionamento	8 Connessioni	9 Revisione prodotto
---------------------------	---------------	----------------------

**B** = Con blocco di stazionamento  
**W** = Senza blocco di stazionamento  
**M** = Funzione di sblocco manuale su freno di stazionamento

**S** = Lato sinistro  
**D** = Lato destro  
**F** = Lato frontale  
**P** = Lato posteriore

Assegnato da UNIVER

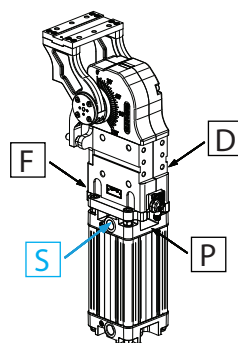

UNIVER SpA raccomanda di far convalidare all'ufficio tecnico UNIVER tutte le applicazioni di Unità Rotanti

## UAGP155OA\_\_BS0

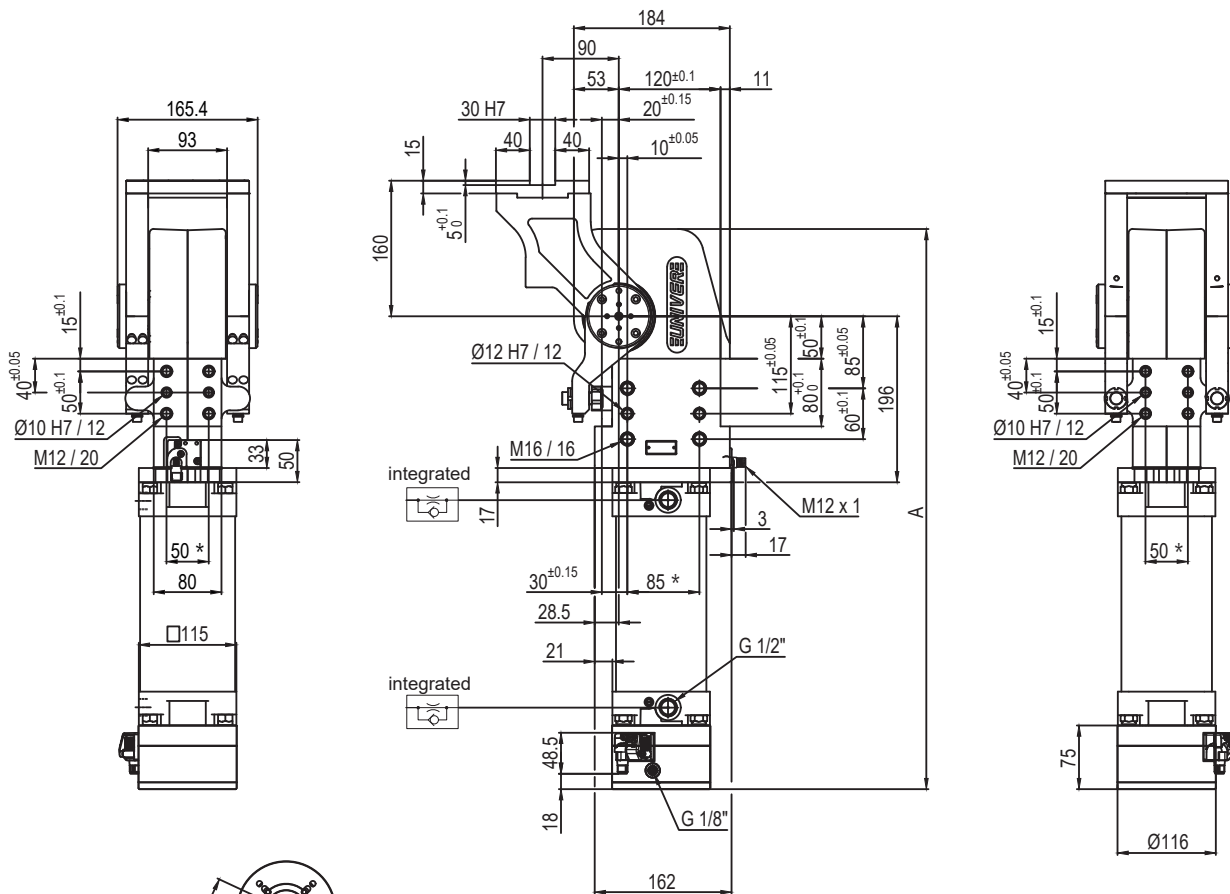

Pivot rotation in degrees	A
45°	583.5
60°	597
90°	628
120°	662.5

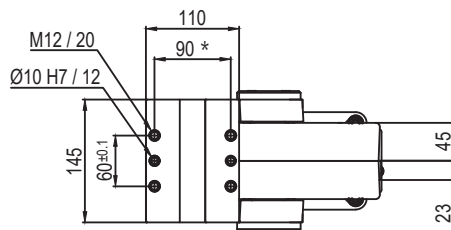

Passive brake

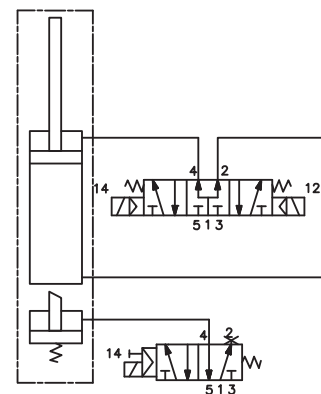

Size	Holding moment	Max. torque at the rotary table 0,55 MPa	Weight
155	6000 Nm	120 Nm	25 Kg

Min./Max. operating pressure: **0,4 / 0,6 MPa**  
 Operating temperature: **5° ÷ 45° C**  
 Predetermine pivot rotation in degrees: **45°- 60°- 90°- 120°**  
 Rotary table position: **Horizontal 90°**  
 Electronic sensor with M12 swivel connector, from 0° or 90°, in steps of 10°  
 Supply voltage: 10 ÷ 30 Vdc  
 IP code: **IP 65**

\*: TOLERANCE BETWEEN DOWEL HOLES ± 0.02, BETWEEN SCREW HOLES ± 0.1

Subject to technical modifications without notice

## UAGP155OK\_\_BS0

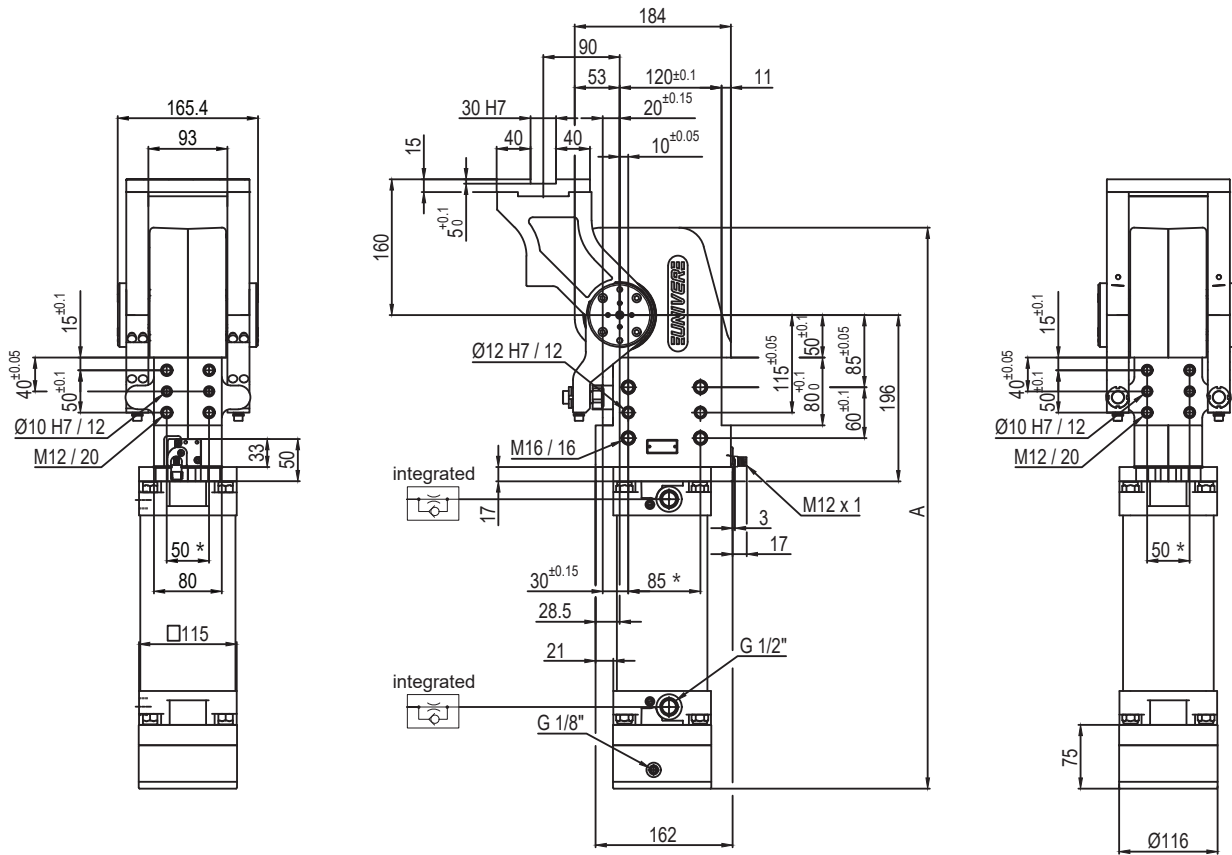

Pivot rotation in degrees	A
45°	583.5
60°	597
90°	628
120°	662.5

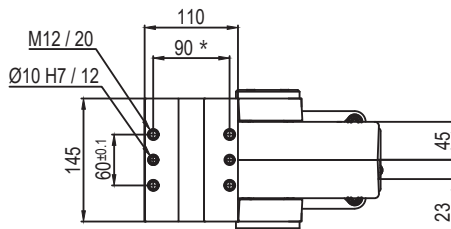

## Passive brake

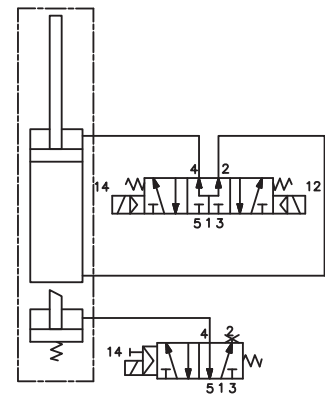

Size	Holding moment	Max. torque at the rotary table 0,55 MPa	Weight
155	6000 Nm	120 Nm	25 Kg

Min./Max. operating pressure: **0,4 / 0,6 MPa**  
 Operating temperature: **5° ÷ 45° C**  
 Predetermine pivot rotation in degrees: **45°- 60°- 90°- 120°**  
 Rotary table position: **Horizontal 90°**  
 Electronic sensor with M12 swivel connector, from 0° or 90°, in steps of 10°  
 Supply voltage: 10 ÷ 30 Vdc  
 IP code: **IP 65**

\*: TOLERANCE BETWEEN DOWEL HOLES ± 0,02, BETWEEN SCREW HOLES ± 0,1

Subject to technical modifications without notice

## UAGP155PA\_\_BS0

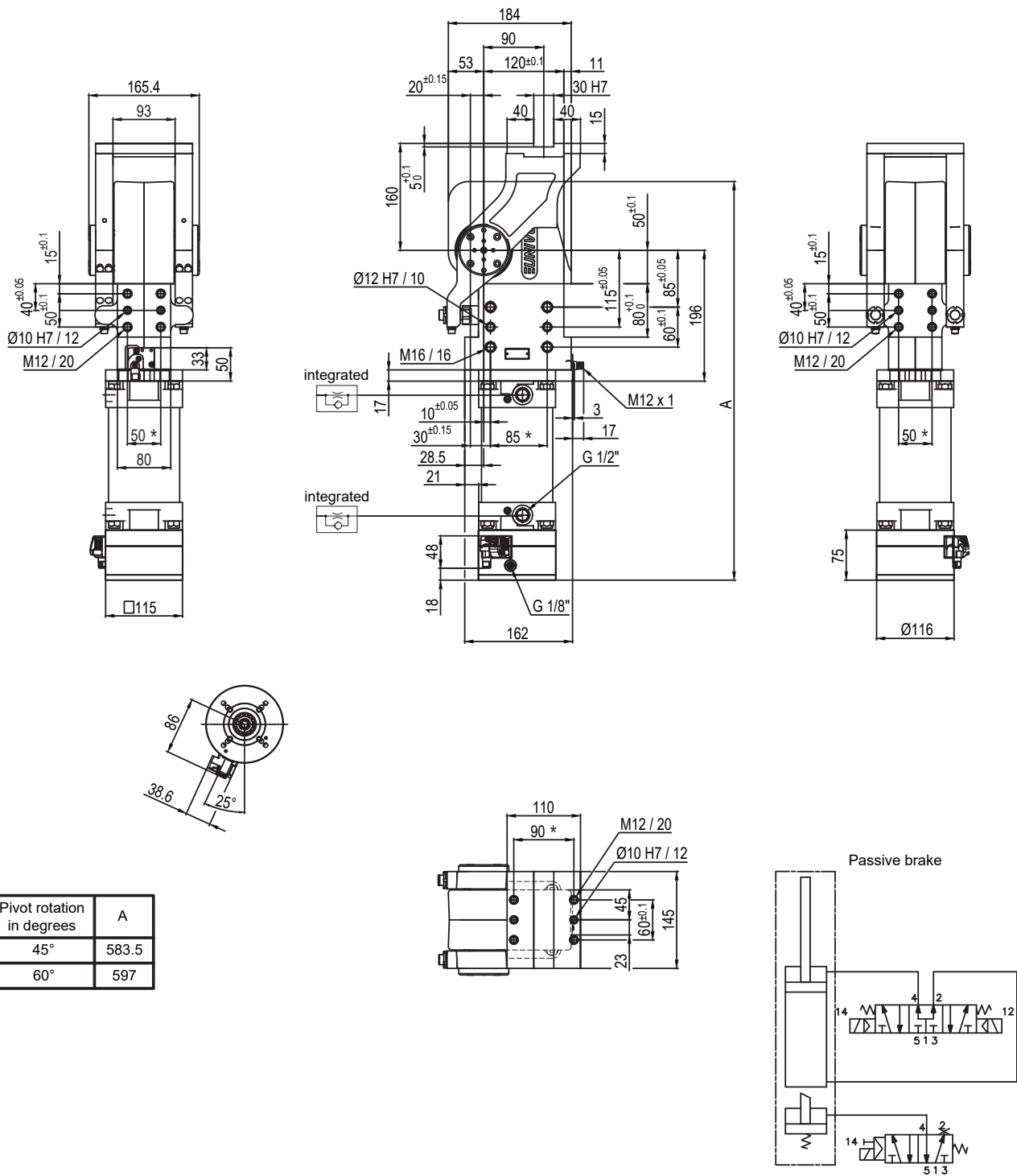

Pivot rotation in degrees	A
45°	583.5
60°	597

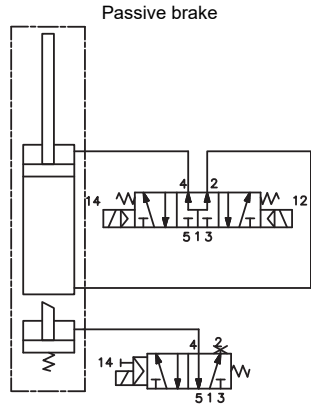

Size	Holding moment	Max. torque at the rotary table 0,55 MPa	Weight
155	6000 Nm	120 Nm	25 Kg

Min./Max. operating pressure: **0,4 / 0,6 MPa**  
 Operating temperature: **5° ÷ 45° C**  
 Predetermine pivot rotation in degrees: **45°- 60°**  
 Rotary table position: **Horizontal mirror of O**  
 Electronic sensor with M12 swivel connector, from 0° or 90°, in steps of 10°  
 Supply voltage: 10 ÷ 30 Vdc  
 IP code: **IP 65**

\*: TOLERANCE BETWEEN DOWEL HOLES ± 0.02, BETWEEN SCREW HOLES ± 0.1

Subject to technical modifications without notice

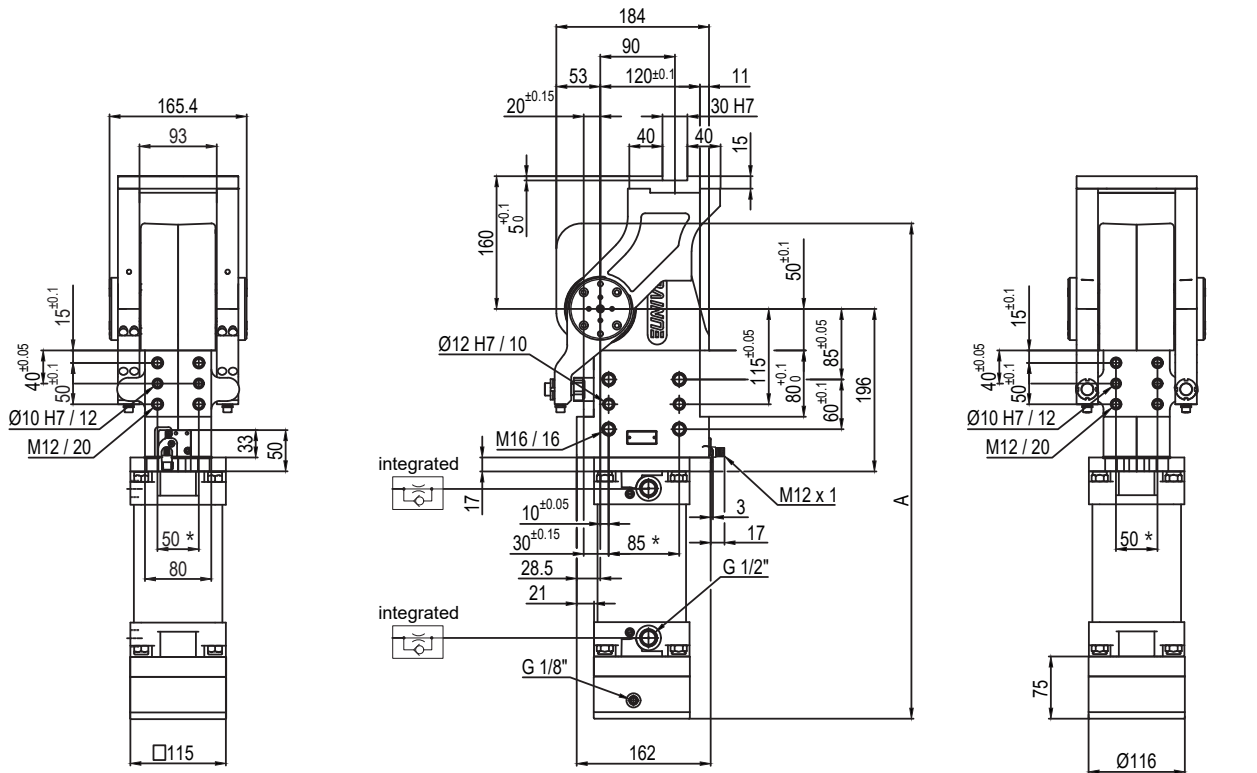
**UAGP155PK\_\_BS0**

Pivot rotation in degrees	A
45°	583.5
60°	597

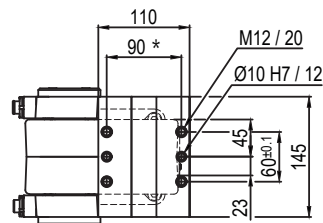

Passive brake

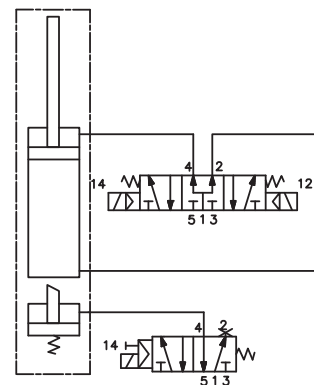

Size	Holding moment	Max. torque at the rotary table 0,55 MPa	Weight
155	6000 Nm	120 Nm	25 Kg

Min./Max. operating pressure: **0,4 / 0,6 MPa**  
 Operating temperature: **5° ÷ 45° C**  
 Predetermine pivot rotation in degrees: **45°- 60°**  
 Rotary table position: **Horizontal mirror of O**  
 Electronic sensor with M12 swivel connector, from 0° or 90°, in steps of 10°  
 Supply voltage: 10 ÷ 30 Vdc  
 IP code: **IP 65**

\*: TOLERANCE BETWEEN DOWEL HOLES ± 0.02, BETWEEN SCREW HOLES ± 0.1

Subject to technical modifications without notice

## UAGP155VA\_\_BS0

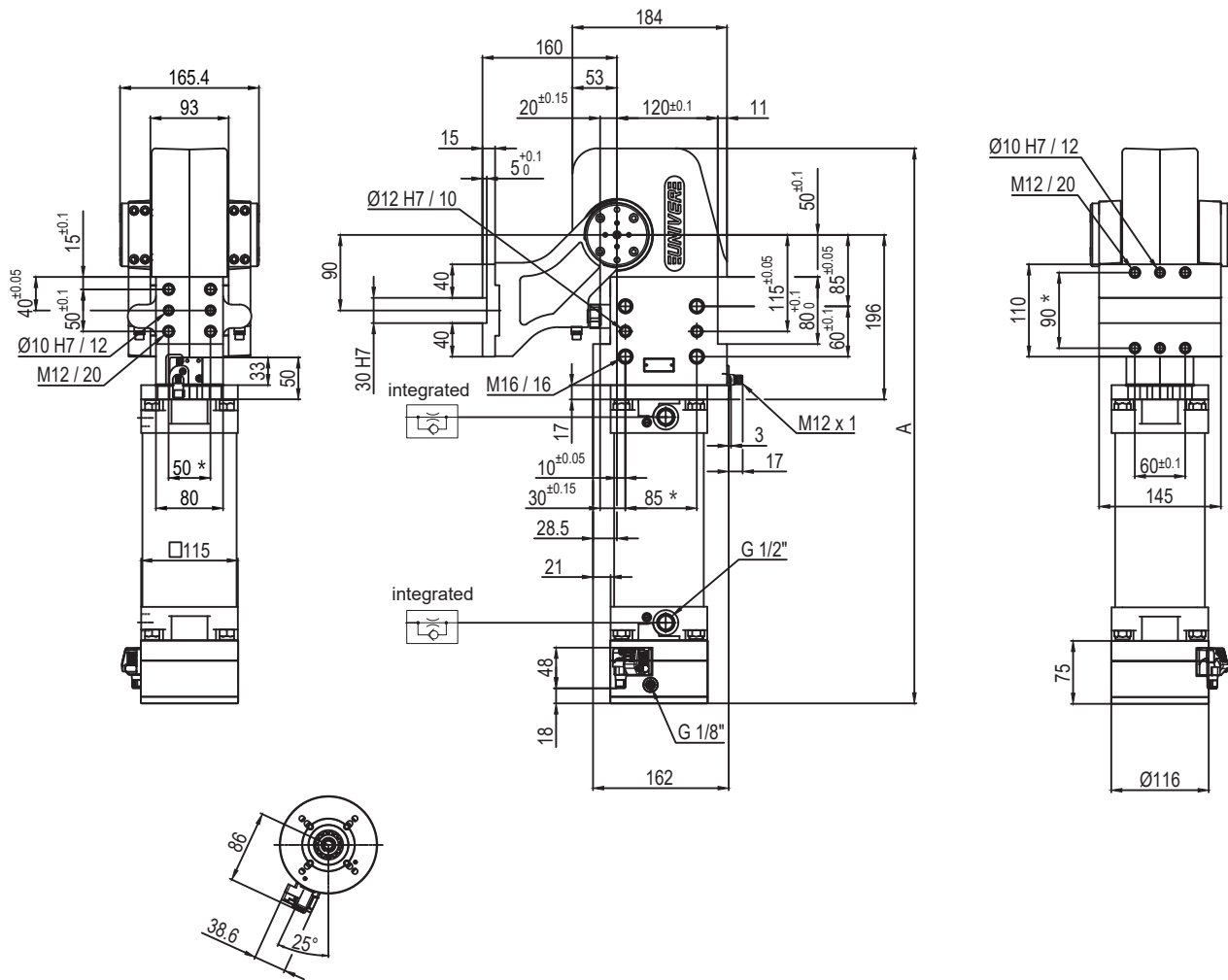

Pivot rotation in degrees	A
45°	583.5
60°	597
90°	628
120°	662.5

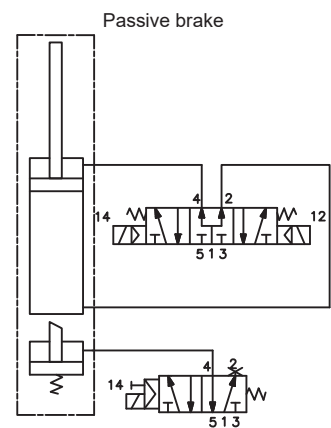
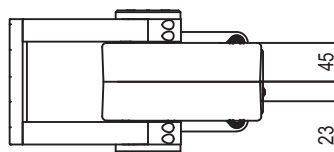

Size	Holding moment	Max. torque at the rotary table 0,55 MPa	Weight
155	6000 Nm	120 Nm	25 Kg

Min./Max. operating pressure: **0,4 / 0,6 MPa**  
 Operating temperature: **5° ÷ 45° C**  
 Predetermine pivot rotation in degrees: **45° - 60° - 90° - 120°**  
 Rotary table position: **Vertical 180°**  
 Electronic sensor with M12 swivel connector, from 0° or 90°, in steps of 10°  
 Supply voltage: 10 ÷ 30 Vdc  
 IP code: **IP 65**

\*: TOLERANCE BETWEEN DOWEL HOLES  $\pm 0,02$ , BETWEEN SCREW HOLES  $\pm 0,1$

Subject to technical modifications without notice



UAGP155ZA\_\_BS0

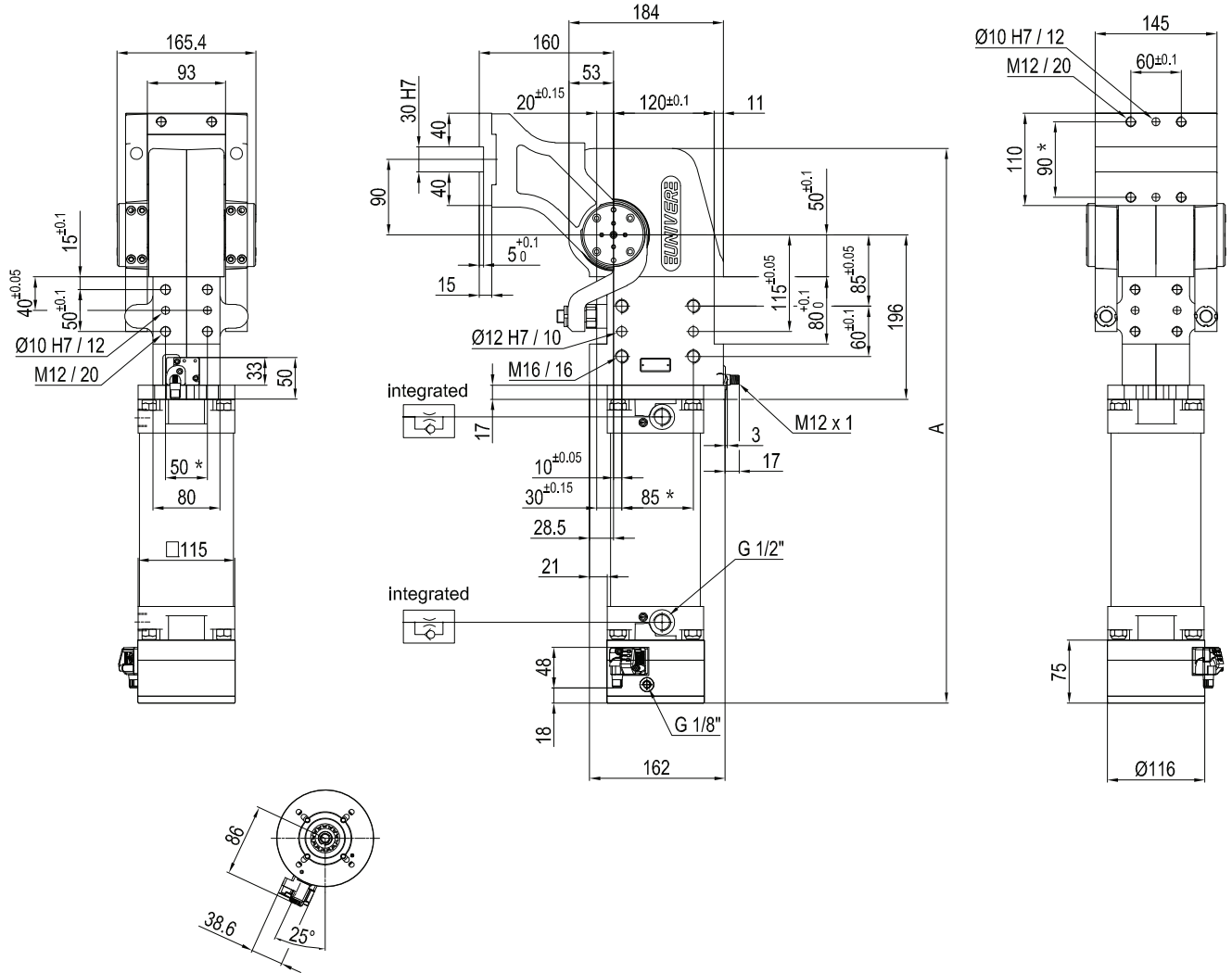

Pivot rotation in degrees	A
45°	583.5
60°	597
90°	628
120°	662.5

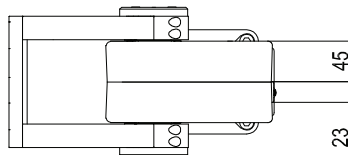

Passive brake

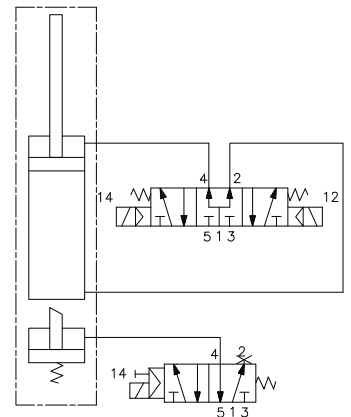

Size	Holding moment	Max. torque at the rotary table 0,55 MPa	Weight
155	6000 Nm	120 Nm	25 Kg

Min./Max. operating pressure: **0,4 / 0,6 MPa**  
 Operating temperature: **5° ÷ 45° C**  
 Predetermine pivot rotation in degrees: **45°- 60° - 90°- 120°**  
 Rotary table position: **Vertical mirror of V**  
 Electronic sensor with M12 swivel connector, from 0° or 90°, in steps of 10°  
 Supply voltage: 10 ÷ 30 Vdc  
 IP code: **IP 65**

\*: TOLERANCE BETWEEN DOWEL HOLES ± 0,02, BETWEEN SCREW HOLES ± 0,1

Subject to technical modifications without notice



