

HTC - Series Clamps - Front Mounting

Straight Line Action

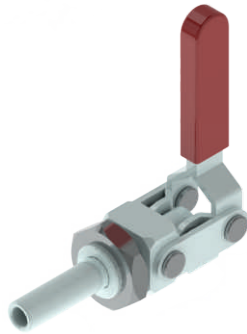

Model No. HTC -190 FM

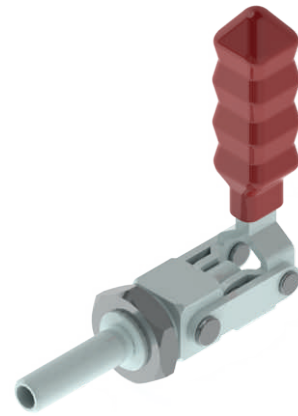

Model No. HTC -350 FM

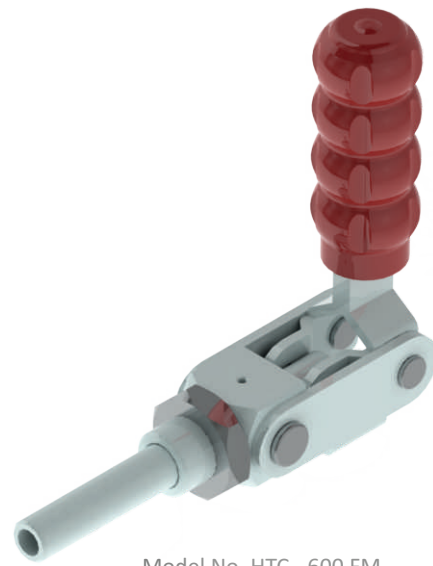
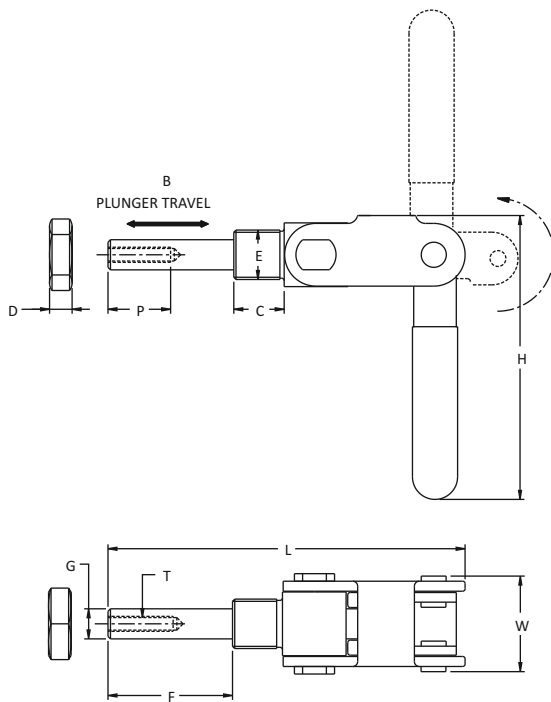

Model No. HTC - 600 FM

Model No.	Plunger Travel B	C	D	Mounting Thread Size E	F	Plunger Dia. G	H	L	P	W	Tapped Hole T	Holding Capacity	Wt. in Kgs
HTC-190 FM	24	11	6	M 16 x 2.0	30	9.5	78	77	25	25	M 6 x 1.0	0.50 kN	0.130
HTC-350 FM	36	15	6	M 20 x 1.5	42	12	103	110	30	31	M 8 x 1.25	1.00 kN	0.260
HTC-600 FM	60	24	10	M 24 x 2.0	62	16	155	175	30	43	M 10 x 1.5	3.40 kN	0.850