

VTC Series Heavy Duty Clamps - Angle Base

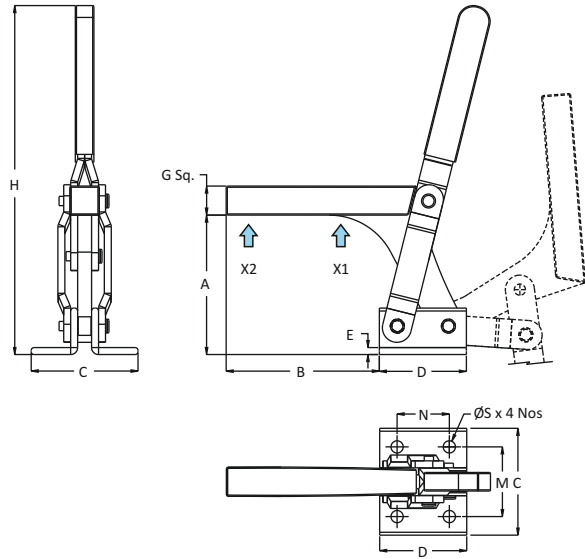

Model No.VTC-6561 A



Supplied with suitable spindle

Model No.	A	B	Mounting Base			G	H	Mounting Dimensions			L	Wt. in Kgs	Handle Moves	Bar Opens	Holding Capacity	
			C	D	E			M	N	ØS					X2	X1
VTC-6561 A	65	60	85	45	5.5	20 x 20	179	55	25	6.5	M10 Bolt	1.000	135°	80°	3.40 kN	4.90 kN